



COURSE OVERVIEW EE0198
API SIEE: Source Inspector - Electrical Equipment
(API Exam Preparation Training)

Course Title

API SIEE: Source Inspector - Electrical Equipment (API Exam Preparation Training)

Course Reference

EE0198

Course Duration/Credits

Five days/4.0 CEUs/40 PDHs



Course Date/Venue

Session(s)	Date	Venue	Exam Window	Exam Registration Closing Date
1	July 06-10, 2025	Club B, Ramada Plaza By Wyndham Istanbul City Center, Istanbul, Turkey	July 11-August 01, 2025	May 02, 2025
2	October 06-10, 2025	Ajman Meeting Room, Grand Millennium Al Wahda Hotel, Abu Dhabi, UAE	November 07-28, 2025	August 29, 2023
3	'December 07-11, 2025	Boardroom 1, Elite Byblos Hotel Al Barsha, Sheikh Zayed Road, Dubai, UAE	TBA	TBA

Exam Venue: Abu Dhabi, Dubai, Al-Khobar, Jeddah, Kuwait, Amman, Beirut, Cairo, Manama & Muscat. Participant has the option to attend at any of the above cities

Course Description



This practical and highly-interactive course includes practical sessions and exercises where participants carryout welding inspection. Theory learnt in the class will be applied using our state-of-the-art simulators.

This course is designed to provide delegates with a detailed and up-to-date overview of API Source Inspector Electrical Equipment (SIEE) (API Exam Preparation Training). It covers the principles of quality management systems, documentation, records and supplier/vendor quality surveillance; the basic electrical safety, relevant electrical standards, certification and markings; the technical documentation, checklists and reporting; the electrical components and visual inspection techniques; and the continuity testing and insulation resistance measurements.



During this interactive course, participants will learn the junction boxes and control panels, electrical systems, distribution panels, boards, grounding and bonding; the types and applications of transformers and testing and fault analysis; the switchgear and motor control centers, electric (over 500 HP) and protective devices and systems; the advanced electrical testing techniques, high-pot testing, partial discharge measurement and thermographic inspections; the failure analysis and troubleshooting, electrical installation inspection and preventive maintenance and reliability; the ATEX/IECEx requirements and hazardous areas classification; and the relevant standards and regulatory and legal requirements.

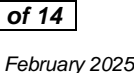
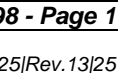
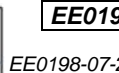

Course Objectives

Upon the successful completion of this course, each participant will be able to:-

- Get prepared for the next API SIEE exam and have enough knowledge and skills to pass such exam in order to get the API SIEE certification
- Discuss the principles of quality management systems and manage documentation, records and supplier/vendor quality surveillance
- Explain basic electrical safety and relevant electrical standards including certification and markings
- Develop an inspection plan and review technical documentation, checklists and reporting
- Identify the electrical components covering cables, wiring, connections and terminations
- Carryout visual inspection techniques, continuity testing and insulation resistance measurements
- Test and verify junction boxes and control panels as well as recognize electrical systems, distribution panels, boards, grounding and bonding
- Identify the types and applications of transformers and apply testing and fault analysis
- Recognize switchgear and motor control centers, electric (over 500 HP) and protective devices and systems
- Apply advanced electrical testing techniques covering high-pot testing, partial discharge measurement and thermographic inspections
- Carryout failure analysis and troubleshooting, electrical installation inspection and preventive maintenance and reliability
- Discuss ATEX/IECEX requirements, classify hazardous areas and inspect hazardous areas equipment
- Review relevant standards like the API, IEEE, IEC and others as well as interpret and apply standards in inspection and discuss regulatory and legal requirements

Exclusive Smart Training Kit - H-STK®



Participants of this course will receive the exclusive “Haward Smart Training Kit” (H-STK®). The H-STK® consists of a comprehensive set of technical content which includes **electronic version** of the course materials conveniently saved in a **Tablet PC**.

Who Should Attend

This course provides an overview of all significant aspects and considerations of API source inspector electrical equipment (SIEE) for electrical inspectors, quality control professionals, engineers, and technicians who are involved in the inspection, testing, and certification of electrical equipment. This includes those who work in industries such as oil and gas, power generation, petrochemical, and aerospace, among others and those who are interested in becoming certified API SIEE inspectors, or those who are required to have this certification as part of their job responsibilities, should attend these courses. Additionally, individuals who are seeking to enhance their knowledge and skills in the area of electrical equipment inspection may also find these courses beneficial.



Exam Eligibility & Structure

Exam Candidates shall have the following minimum pre-requisites:-

Education	Years of Experience	Experience Required
High School Diploma/GED (equivalent)	5 years	<ul style="list-style-type: none"> Electrical inspection experience Non-inspection electrical experience General inspection with some electrical experience Journeyman and Master Electrician would qualify under 5 years
High School Diploma/GED (equivalent) + SIFE or SIRE	3 years	<ul style="list-style-type: none"> Electrical inspection experience Non-inspection electrical experience General inspection with some electrical experience
4-year Military Experience <i>(Dishonorable discharge disqualifies credit)</i>	3 years	<ul style="list-style-type: none"> Electrical inspection experience Non-inspection electrical experience General inspection with some electrical experience
2-year Electrical/Electronic Technology degree/certificate	3 years	<ul style="list-style-type: none"> Electrical inspection experience Non-inspection electrical experience General inspection with some electrical experience
4-year Military Experience with 2 years of Electrical/Electronic MOS (Military operations specialty code) <i>(Dishonorable discharge disqualifies credit)</i>	2 years	<ul style="list-style-type: none"> Electrical inspection experience Non-inspection electrical experience General inspection with some electrical experience
BS in Electrical/Electronic Engineering	2 years	<ul style="list-style-type: none"> Electrical inspection experience Non-inspection electrical experience General inspection with some electrical experience

1. Electrical Inspection - Oil & Gas, power, nuclear, military, commercial, residential, utility, industrial inspection

- Electrical skid mounted equipment
- Transformers
- Switchgears
- Medium voltage switchgears
- Electrical induction motors 500 HP and larger

2. Non-inspection Electrical Experience - Oil & Gas, power, nuclear, military, commercial, residential, utility, industrial experience

- Electricians working in power plants including nuclear, fossil fuels and renewables
- Electrical engineers and technicians with manufacturing, construction, maintenance or commissioning experience, with a focus on electrical/industrial power
- Licensed Electrical Journeyman
- Licensed Master Electrician
- Experience working with transformers and switchgears
 - Includes: Traction Power Technician, Substation Engineer, Relay Engineer/Technician, Groundman, Electrical-Industrial Journeyman, Electrical Testing & Commissioning Specialist
 - Excludes: Lineman, Power Line Technician, Journeyman Lineman, Line Installers and Repairers, unassigned lineman (UAL), Line Mechanic



3. General Inspection with some Electrical Experience - skid packages, definable experience with electrical

- Source Inspectors of Fixed or Rotating Equipment with Electrical Experience

Required Codes & Standards

Listed below are the effective editions of the publications required for this exam for the date(s) shown above. **Each participant must purchase these documents separately and have them available for use during the class as their cost is not included in the course fees:-**

API Documents

- **Guide for Source Inspection and Quality Surveillance of Electrical Equipment**
 - Entire document is subject to testing.
- **API Recommended Practice 540, Electrical Installations in Petroleum Processing Plants**, 4th Edition, April 1999, Reaffirmed August 2013
 - Only Sections 1, 2 and 8 are subject to testing.
- **API Standard 541, Form-wound Squirrel Cage Induction Motors- 375 kW (500 Horsepower) and Larger**, 5th Edition, December 2014, Reaffirmed May 2021
 - Entire document is subject to testing with the exception of the annexes.
- **API Recommended Practice 14F, Design, Installation, and Maintenance of Electrical Systems for Fixed and Floating Offshore Petroleum Facilities for Unclassified and Class 1, Division 1 and Division 2 Locations**, 6th Edition, October 2018
 - Entire document is subject to testing.
- **API Recommended Practice 14FZ, Design, Installation, and Maintenance of Electrical Systems for Fixed and Floating Offshore Petroleum Facilities for Unclassified and Class I, Zone 0, Zone 1, and Zone 2 Locations**, 2nd Edition, Reaffirmed April 2020
 - Only Sections 1, 3 and 6 are subject to testing

Institute of Electrical and Electronics Engineers (IEEE)

- **IEEE 141, Recommended Practice for Electric Power Distribution for Industrial Plants**, 1993 Edition, 1993
 - Only Sections 1 and 10 are subject to testing
- **IEEE 841, Standard for Petroleum and Chemical Industry--Premium-Efficiency, Severe-Duty, Totally Enclosed Squirrel Cage Induction Motors from 0.75 kW to 370 kW (1 hp to 500 hp)**, 2021 Edition, May 2021
 - Only Sections 1, 5, 6, 8, 9 and 10 and Annex 1 are subject to testing
- **IEEE C37.20.1a, Metal-Enclosed Low-Voltage (1000 V ac and below, 3200 V dc and below) Power Circuit Breaker Switchgear – Amendment 1: Control and Secondary Circuits and Devices, and All Wiring**, 2020 Edition, May 2020
 - Only Sections 5-7 are subject to testing
- **ANSI/IEEE C37.20.3, Metal-Enclosed Interrupter Switchgear (1 kV–38 kV)**, 2013 Edition, December 2013
 - Only Section 7 is subject to testing
- **ANSI/IEEE C57.12.00, General Requirements for Liquid-Immersed Distribution, Power, and Regulating Transformers**, 2021 Edition, January 2022
 - Only Sections 4-6 and 9 are subject to testing.



National Electrical Manufacturers Association (NEMA)

- **NEMA ICS 1**, *Industrial Control and Systems: General Requirements*, 2000 Edition, Reaffirmed 2015
 - Sections 1 through 8 and Annex A are subject to testing. All other annexes are excluded
- **NEMA ICS 2**, *Controllers, Contactors and Overload Relays Rated 600 V*, 2000 Edition, Reaffirmed 2020
 - Sections 1, 6 8 & 9 are subject to testing
- **NEMA ICS 3**, *Medium Voltage Controllers Rated 2,001 to 7,200 V AC*, 2005 Edition, Reaffirmed 2010
 - Entire document is subject to testing.
- **NEMA ICS 19**, *Diagrams, Device Designations and Symbols*, 2002 Edition, Reaffirmed 2022
 - Entire document is subject to testing
- **NEMA MG-1**, *Motors and Generators*, 2021 Edition
 - Only Section 1 (Parts 1 and 7), Section III (Part 20) and Section IV (Part 30) are subject to testing

International Electrical Testing Association (NETA)

- **NETA ATS**, *Standard for Acceptance Testing Specifications for Electrical Power Equipment and Systems*, May 2017
 - Only Sections 4, 5 and 7 are subject to testing.

National Fire Protection Association (NFPA)

- **NFPA 70**, *National Electrical Code*, 2020 Edition
 - Chapters 1 through 4, and Chapter 5, Sections 500-506 are subject to testing
- **NFPA 70E**, *Standard for Electrical Safety in the Workplace*, 2021 Edition
 - Only the Introduction and Chapter 1 and Chapter 3, sections 300-340 are subject to testing.

Note: API and ASME publications are copyrighted material. Photocopies of API and ASME publications are not permitted.

In an unlikely event, the course instructor may modify the above training methodology before or during the course for technical reasons.

Training Methodology

All our Courses are including **Hands-on Practical Sessions** using equipment, State-of-the-Art Simulators, Drawings, Case Studies, Videos and Exercises. The courses include the following training methodologies as a percentage of the total tuition hours:-

- 30% Lectures
- 20% Practical Workshops & Work Presentations
- 30% Hands-on Practical Exercises & Case Studies
- 20% Simulators (Hardware & Software) & Videos

In an unlikely event, the course instructor may modify the above training methodology before or during the course for technical reasons.



API Certificate(s)

- (1) API-SIEE certificate will be issued to participants who have successfully passed the API-SIEE examination.



- (2) Official Transcript of Records will be provided to the successful delegates with the equivalent number of ANSI/IACET accredited Continuing Education Units (CEUs) earned during the course.

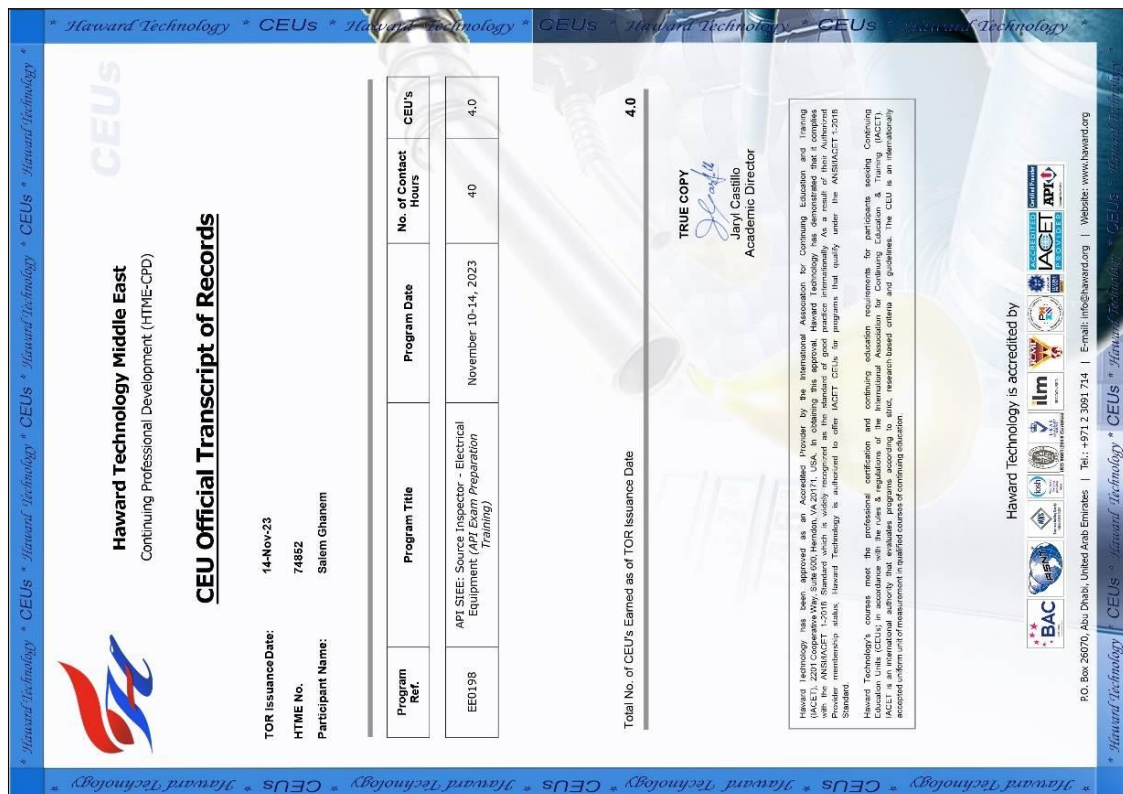



Certificate Accreditations

Certificates are accredited by the following international accreditation organizations:

- 
The International Accreditors for Continuing Education and Training (IACET - USA)

Haward Technology is an Authorized Training Provider by the International Accreditors for Continuing Education and Training (IACET), 2201 Cooperative Way, Suite 600, Herndon, VA 20171, USA. In obtaining this authority, Haward Technology has demonstrated that it complies with the **ANSI/IACET 2018-1 Standard** which is widely recognized as the standard of good practice internationally. As a result of our Authorized Provider membership status, Haward Technology is authorized to offer IACET CEUs for its programs that qualify under the **ANSI/IACET 2018-1 Standard**.

Haward Technology’s courses meet the professional certification and continuing education requirements for participants seeking **Continuing Education Units (CEUs)** in accordance with the rules & regulations of the International Accreditors for Continuing Education & Training (IACET). IACET is an international authority that evaluates programs according to strict, research-based criteria and guidelines. The CEU is an internationally accepted uniform unit of measurement in qualified courses of continuing education.

Haward Technology Middle East will award **4.0 CEUs** (Continuing Education Units) or **40 PDHs** (Professional Development Hours) for participants who completed the total tuition hours of this program. One CEU is equivalent to ten Professional Development Hours (PDHs) or ten contact hours of the participation in and completion of Haward Technology programs. A permanent record of a participant’s involvement and awarding of CEU will be maintained by Haward Technology. Haward Technology will provide a copy of the participant’s CEU and PDH Transcript of Records upon request.

- 
British Accreditation Council (BAC)

Haward Technology is accredited by the **British Accreditation Council** for **Independent Further and Higher Education** as an **International Centre**. BAC is the British accrediting body responsible for setting standards within independent further and higher education sector in the UK and overseas. As a BAC-accredited international centre, Haward Technology meets all of the international higher education criteria and standards set by BAC.

Course Fee

Istanbul	US\$ 8,000 per Delegate + VAT . This rate includes Participants Pack (Folder, Manual, Hand-outs, etc.), buffet lunch, coffee/tea on arrival, morning & afternoon of each day.
Abu Dhabi	US\$ 7,500 per Delegate + VAT . This rate includes Participants Pack (Folder, Manual, Hand-outs, etc.), buffet lunch, coffee/tea on arrival, morning & afternoon of each day.
Dubai	US\$ 7,500 per Delegate + VAT . This rate includes Participants Pack (Folder, Manual, Hand-outs, etc.), buffet lunch, coffee/tea on arrival, morning & afternoon of each day.

Exam Fee

US\$ 620 per Delegate.



Course Instructor(s)

This course will be conducted by the following instructor(s). However, we have the right to change the course instructor(s) prior to the course date and inform participants accordingly:



Mr. Ahmed Alaa, MSc, BSc, API-SIEE is a **Senior Electrical & Instrumentation Engineer** with extensive years of experience within the **Oil, Gas, Petrochemical, Refinery & Power** industries. His expertise widely covers in the areas of API Source Inspector Electrical Equipment, Electrical Equipment Inspection, **HV/MV Cable Splicing, Cable & Over Head Power Line, HV/MV Switchgear, HV Cable Design, Cable Splicing & Termination, High Voltage Electrical Safety, Medium & High Voltage Equipment, High Voltage Circuit Breaker** Inspection & Repair, **High Voltage Power System, HV Equipment** Inspection & Maintenance, **HV Switchgear** Operation & Maintenance, Resin / **Heat Shrink & Cold Shrink** Joints, **HV/LV Equipment, LV & HV Electrical System, LV, MV & HV Cable** Installations & Properties, ORHVS for Responsible and Authorized Person **High Voltage Regulation, Transformers** Maintenance, inspections & repairs, Commissioning of **LV & HV Equipment**, Electrical Transient Analysis Program (ETAP), Programmable Logic Control (**PLC**), PLC for Process Control & Automation, Programmable Logic Controller (**PLC**) Operations, Maintenance and Troubleshooting, Programmable Logic Controllers (**PLC**), **PLC** Basics to Advanced Application, Power Management System (**PMS**), Variable Speed Drive (**VSD**), Advanced **ABB VSD** Controllers, **VSD** commissioning and troubleshooting, Power Management System (**PMS**), Marine Vessel Power Management Systems, Electrical Equipment & Control System, Ex Equipment, **Power System Operation and Control**, Fault Analysis in **Power Systems, LV & MV** Electric Power Systems for Industrial Plants, Electric Power System Operation, **Electric Motors & Variable Speed Drives, Electric Motor** Selection, Maintenance & Control, **Motor Operation & Maintenance, Electric Motor Protection, UPS** and **Battery** System, **UPS & Battery** Design, Operation, Maintenance & Troubleshooting, **UPS, DC System & Battery** Design, Operation, Maintenance & Troubleshooting Testing & Maintenance, Installing and Testing **Electric Wires & Cables**, Cable Jointing Appreciation, **Circuit Breaker & Switchgear, Transformer & Circuit Breakers** Testing & Maintenance and **Motor Control Circuit** Troubleshooting.

During Mr. Ahmed's career life, he has gained his practical experience through several significant positions and dedication as the **Senior Electrical Engineer, Electromechanical Engineer, Electrical Maintenance Engineer, Electrical Instructor** and **Instructor/Trainer** from various companies like the Khalda Petroleum Company, Qarun Petroleum Company, Arab Contractor Company and Uniplast Company.

Mr. Ahmed has a **Bachelor's** degree in **Electrical Engineering**. Further, he is a **Certified Instructor/Trainer** and a **Certified API Source Inspector Electrical Equipment (SIEE)**. He has further delivered numerous trainings, courses, workshops, seminars and conferences internationally.



Course Program

The following program is planned for this course. However, the course instructor(s) may modify this program before or during the course for technical reasons with no prior notice to participants. Nevertheless, the course objectives will always be met:

Day 1

0730 – 0800	Registration & Coffee
0800 – 0815	Welcome & Introduction
0815 – 0830	PRE-TEST
0830 – 1000	Overview of API SIEE Certification Purpose & Scope • Certification Process • Examination Overview
1000 – 1015	Break
1015 – 1130	Quality Management Systems Principles of Quality Management • Documentation & Records • Supplier/Vendor Quality Surveillance
1130 - 1230	Electrical Safety & Standards Basic Electrical Safety • Relevant Electrical Standards (e.g., IEEE, IEC) • Certifications and Markings
1230 – 1330	Lunch
1330 – 1430	Inspection Planning & Documentation Developing an Inspection Plan • Reviewing Technical Documentation • Checklists & Reporting
1430 - 1515	Electrical Components Cables and Wiring • Connectors & Terminations
1515 – 1530	Break
1530 – 1650	Basic Electrical Testing Methods Visual Inspection Techniques • Continuity Testing • Insulation Resistance Measurements
1650 – 1700	Recap Using this Course Overview, the Instructor(s) will Brief Participants about the Topics that were Discussed Today & Advise Them of the Topics to be Discussed Tomorrow
1700	End of Day One

Day 2

0730 – 0830	Junction Boxes & Control Panels Inspection Criteria • Installation Requirements • Testing & Verification
0830 – 1000	Electrical Systems & Distribution Overview of Electrical Systems • Distribution Panels & Boards • Grounding & Bonding
1000 – 1015	Break
1015 – 1130	Transformers Types & Applications • Cooling & Insulation • Testing & Fault Analysis
1130 – 1230	Switchgear & Motor Control Centers Components & Operation • Inspection Points • Maintenance & Testing
1230 – 1330	Lunch
1330 – 1515	Electric Motors (over 500 HP) Construction & Types • Performance Characteristics • Inspection & Testing
1515 – 1530	Break



1530 – 1650	Protective Devices & Systems Circuit Breakers and Fuses • Relay Protection Systems • Inspection and Testing
1650 – 1700	Recap Using this Course Overview, the Instructor will Brief Participants about the Topics that were Discussed Today and Advise Them of the Topics to be Discussed Tomorrow
1700	End of Day Two

Day 3

0730 – 0830	Advanced Electrical Testing Techniques High-Pot Testing • Partial Discharge Measurement • Thermographic Inspections
0830 – 1000	Failure Analysis & Troubleshooting Common Electrical Equipment Failures • Troubleshooting Methods • Case Studies
1000 – 1015	Break
1015 – 1130	Electrical Installation Inspection Standards and Codes • Installation Practices • Final Acceptance Testing
1130 – 1230	Preventive Maintenance & Reliability Maintenance Strategies • Reliability-Centered Maintenance • Condition Monitoring
1230 – 1330	Lunch
1330 – 1515	Hazardous Areas & Equipment ATEX/IECEX Requirements • Classification of Hazardous Areas • Inspection of Equipment for Hazardous Areas
1515 – 1530	Break
1530 – 1650	Energy Efficiency & Sustainability Energy Efficiency in Electrical Systems • Sustainable Practices • Impact on Inspections
1650 – 1700	Recap Using this Course Overview, the Instructor will Brief Participants about the Topics that were Discussed Today and Advise Them of the Topics to be Discussed Tomorrow
1700	End of Day Three

Day 4

0730 – 0830	Detailed Review of Relevant Standards API • IEEE • IEC and Others
0830 – 1000	Interpreting & Applying Standards Case studies • Application in Inspections
1000 – 1015	Break
1015 – 1130	Regulatory & Legal Requirements Understanding Compliance • International Regulations
1130 – 1230	Updates & Changes in Standards Keeping Up-to-date • Impact on Inspection Practices
1230 – 1330	Lunch
1330 – 1515	Standards for Special Equipment Solar Panels • Wind Turbines • Battery Storage
1515 – 1530	Break



1530 – 1650	Workshop: Applying Codes & Standards Practical Exercises • Group Discussions
1650 – 1700	Recap Using this Course Overview, the Instructor will Brief Participants about the Topics that were Discussed Today and Advise Them of the Topics to be Discussed Tomorrow
1700	End of Day Four

Day 5

0730 – 0830	Exam Overview & Tips Exam Format • Study Strategies • Time Management
0830 – 1000	Sample Exam Questions & Answers Practice Sessions • Discussion of Answers
1000 – 1015	Break
1015 – 1130	Critical Thinking & Analysis Approaching Complex Questions • Analytical Techniques
1130 - 1215	Review of Key Topics High-Yield Topics • Areas of Focus
1215 - 1315	Lunch
1315 - 1530	Open Forum & Q&A Addressing Participant Questions • Clarification of Doubts
1530 - 1545	Break
1545 - 1615	Final Preparation & Relaxation Techniques Stress Management • Exam Day Preparation • Relaxation Techniques
1615 - 1630	Course Conclusion Using this Course Overview, the Instructor will Brief Participants about the Course Topics that were Covered During the Course
1630 – 1645	POST-TEST
1645 – 1700	Presentation of Course Certificates
1700	End of Course

MOCK Exam

Upon the completion of the course, participants have to sit for a MOCK Examination similar to the exam of the Certification Body through Haward’s Portal. Each participant will be given a username and password to log in Haward’s Portal for the MOCK Exam during the 30 days following the course completion. Each participant has only one trial for the MOCK exam within this 30-day examination window. Hence, you have to prepare yourself very well before starting your MOCK exam as this exam is a simulation to the one of the Certification Body.

Simulator (Hands-on Practical Sessions)

Practical sessions will be organized during the course for delegates to practice the theory learnt. Delegates will be provided with an opportunity to carryout various exercises using our state-of-the-art simulators “Troubleshooting Electrical Circuits V4.1”, Power World” and “ETAP software”.

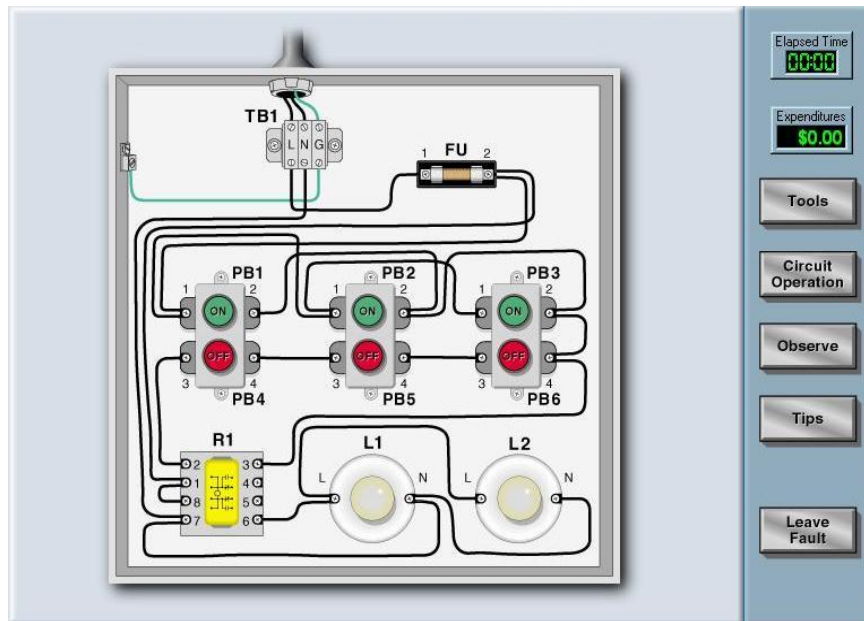

Basic Techniques

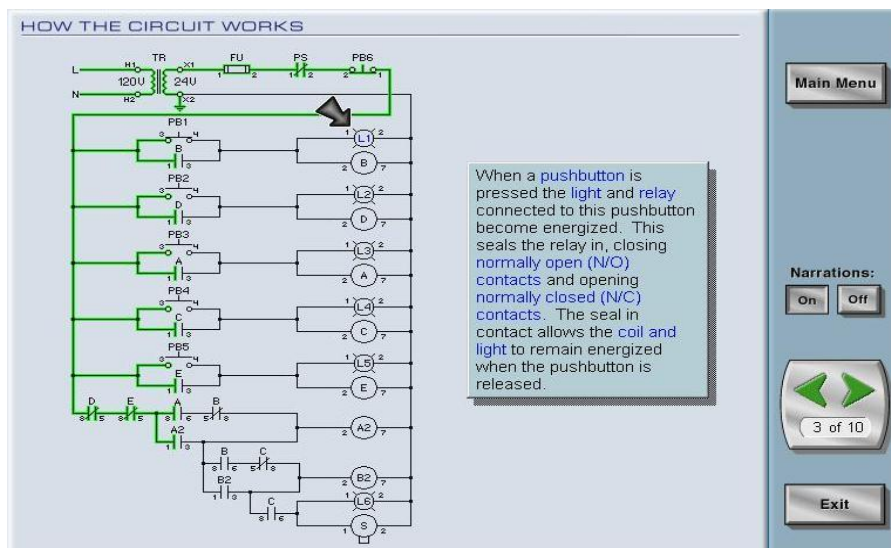

Basic Control Circuits



Motor Control Techniques

Power World Simulator

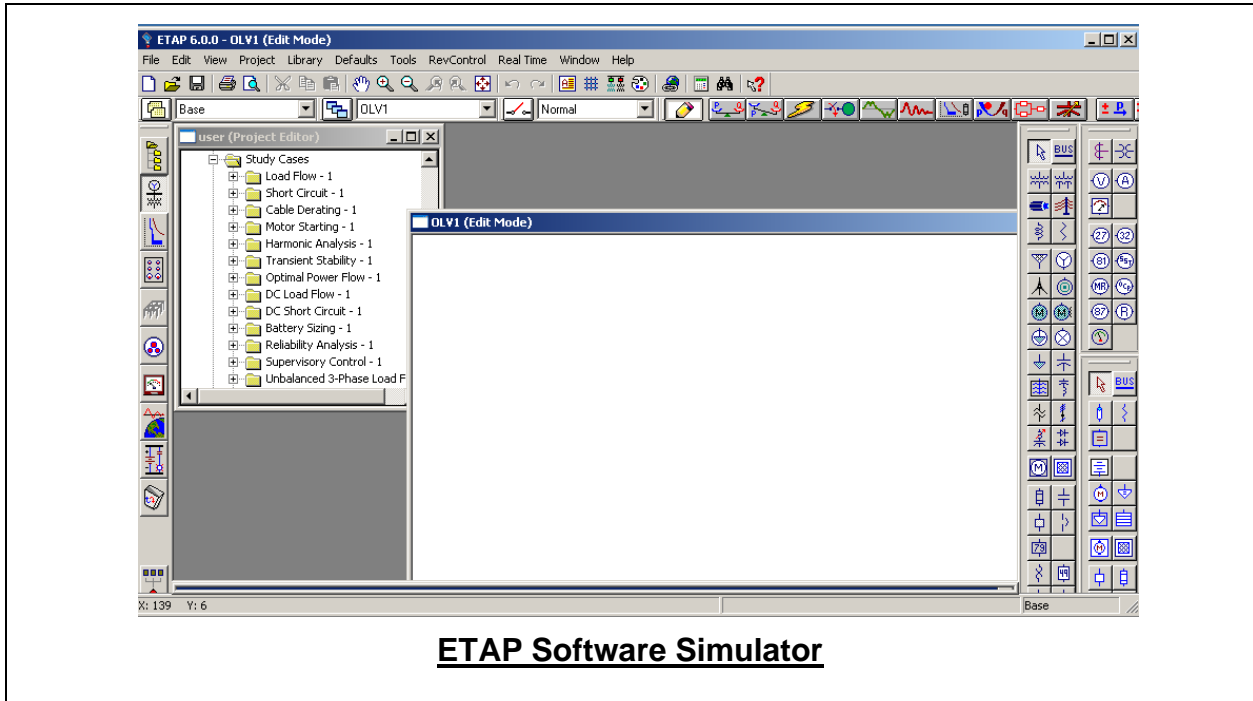

Course Coordinator

Mari Nakintu, Tel: +971 2 30 91 714, Email: mari1@haward.org