

COURSE OVERVIEW EE0852
Electrical & Instrumentation Inspection (Certification)

Course Title

Electrical & Instrumentation Inspection (Certification)

Course Date/Venue

February 16-20, 2025/Slaysel 02 Meeting Room, Movenpick Hotel & Resort Al Bida'a Kuwait, City of Kuwait

Course Reference

EE0852

Course Duration/Credits

Five days/3.0 CEUs/30PDHs

Course Description



This practical and highly-interactive course includes various practical sessions and exercises. Theory learnt will be applied using our state-of-the-art simulators.

This course is designed to provide delegates with an up-to-date overview of certified electrical and instrumentation inspector. It covers the comprehensive knowledge, general requirements inspections, electrical and instrument document, material selection, installation and safety checklist for electrical inspections; the general wiring methods and identify boxes and conduit boxes, cabinets and cutout boxes, switches and receptacles, services, feeders and branch circuits; and the grounding and bonding and identify the general electrical inspection checklists.

During this interactive course, participants will learn the commercial and industrial inspections for motors, transformers, capacitors, signs and outline lighting; the hazardous locations checklist, instrument controller, piping and instrument diagram; the fire and gas detection and ESD (emergency shutdown) procedures and telecommunication; and the Calibration and function test instrument and identify hazardous location as well as basic and regulation inspection.

Course Objectives

Upon the successful completion of this course, each participant will be able to:-

- Get certified as a “*Certified Electrical and Instrumentation Inspector*”
- Apply and gain a comprehensive knowledge on electrical and instrumentation inspection
- Recognize the general requirements inspections, electrical and instrument document, material selection, installation and safety checklist for electrical inspections
- Explain the general wiring methods and identify boxes and conduit boxes, cabinets and cutout boxes, switches and receptacles, services, feeders and branch circuits
- Describe grounding and bonding and identify the general electrical inspection checklists
- Carryout commercial and industrial inspections for motors, transformers, capacitors, signs and outline lighting
- Illustrate hazardous locations checklist, instrument controller, piping and instrument diagram
- Employ fire and gas detection and ESD (emergency shutdown) procedures and telecommunication
- Calibrate and function test instrument and identify hazardous location as well as basic and regulation inspection

Exclusive Smart Training Kit - H-STK®



Participants of this course will receive the exclusive “Haward Smart Training Kit” (H-STK®). The H-STK® consists of a comprehensive set of technical content which includes **electronic version** of the course materials conveniently saved in a **Tablet PC**.

Who Should Attend

This course provides an overview of all significant aspects and considerations of electrical and instrumentation inspection of instruments and electrical measuring equipment for those who are involved in the field of electrical and instrumentation inspection including inspection engineers, electrical engineers, electrical inspection engineers and instrumentation engineers. Further, this course is also beneficial to those engineers who are vital participants in industrial settings and those who are familiar with electrical devices, their function and the standards of operation set by the engineering industry.

Course Certificate(s)

(1) Internationally recognized Competency Certificates and Plastic Wallet Card Certificates will be issued to participants who completed a minimum of 80% of the total tuition hours and successfully passed the exam at the end of the course. Certificates are valid for 5 years.

Recertification is FOC for a Lifetime.

Sample of Certificates

The following are samples of the certificates that will be awarded to course participants: -



- (2) Official Transcript of Records will be provided to the successful delegates with the equivalent number of ANSI/IACET accredited Continuing Education Units (CEUs) earned during the course.

* Haward Technology * CEUs * Haward Technology * CEUs * Haward Technology * CEUs * Haward Technology *



Haward Technology Middle East

Continuing Professional Development (HTME-CPD)

CEUs

Page 1 of 1

CEU Official Transcript of Records

TOR Issuance Date: 14-Nov-19

HTME No. 8667-2014-9020-2555

Participant Name: Abdulsatar Al Otaibi

Program Ref.	Program Title	Program Date	No. of Contact Hours	CEU's
EE0852	Electrical and Instrumentation Inspection (Certification)	November 10-14, 2019	30	3.0
Total No. of CEU's Earned as of TOR Issuance Date				3.0

TRUE COPY



Maricel De Guzman
Academic Director

Haward Technology has been approved as an Authorized Provider by the International Association for Continuing Education and Training (IACET), 2201 Cooperative Way, Suite 800, Herndon, VA 20171, USA. In obtaining this approval, Haward Technology has demonstrated that it complies with the ANSI/IACET 1-2013 Standard which is widely recognized as the standard of good practice internationally. As a result of their Authorized Provider membership status, Haward Technology is authorized to offer IACET CEUs for programs that qualify under the ANSI/IACET 1-2013 Standard.

Haward Technology's courses meet the professional certification and continuing education requirements for participants seeking Continuing Education Units (CEUs) in accordance with the rules & regulations of the International Association for Continuing Education & Training (IACET). IACET is an international authority that evaluates programs according to strict, research-based criteria and guidelines. The CEU is an internationally accepted uniform unit of measurement in qualified courses of continuing education.

Haward Technology is accredited by









P.O. Box 26070, Abu Dhabi, United Arab Emirates | Tel.: +971 2 3091 714 | Fax: +971 2 3091 716 | E-mail: info@haward.org | Website: www.haward.org

* Haward Technology * CEUs * Haward Technology * CEUs * Haward Technology * CEUs * Haward Technology *

Certificate Accreditations

Certificates are accredited by the following international accreditation organizations: -

- 
British Accreditation Council (BAC)

Haward Technology is accredited by the **British Accreditation Council** for **Independent Further and Higher Education** as an **International Centre**. BAC is the British accrediting body responsible for setting standards within independent further and higher education sector in the UK and overseas. As a BAC-accredited international centre, Haward Technology meets all of the international higher education criteria and standards set by BAC.

- 
The International Accreditors for Continuing Education and Training (IACET - USA)

Haward Technology is an Authorized Training Provider by the International Accreditors for Continuing Education and Training (IACET), 2201 Cooperative Way, Suite 600, Herndon, VA 20171, USA. In obtaining this authority, Haward Technology has demonstrated that it complies with the **ANSI/IACET 2018-1 Standard** which is widely recognized as the standard of good practice internationally. As a result of our Authorized Provider membership status, Haward Technology is authorized to offer IACET CEUs for its programs that qualify under the **ANSI/IACET 2018-1 Standard**.

Haward Technology's courses meet the professional certification and continuing education requirements for participants seeking **Continuing Education Units (CEUs)** in accordance with the rules & regulations of the International Accreditors for Continuing Education & Training (IACET). IACET is an international authority that evaluates programs according to strict, research-based criteria and guidelines. The CEU is an internationally accepted uniform unit of measurement in qualified courses of continuing education.

Haward Technology Middle East will award **3.0 CEUs** (Continuing Education Units) or **30 PDHs** (Professional Development Hours) for participants who completed the total tuition hours of this program. One CEU is equivalent to ten Professional Development Hours (PDHs) or ten contact hours of the participation in and completion of Haward Technology programs. A permanent record of a participant's involvement and awarding of CEU will be maintained by Haward Technology. Haward Technology will provide a copy of the participant's CEU and PDH Transcript of Records upon request.

Course Instructor(s)

This course will be conducted by the following instructor(s). However, we have the right to change the course instructor(s) prior to the course date and inform participants accordingly:



Mr. Pan Marave, PE, MSc, BEng, is a Senior Electrical & Instrumentation Engineer with over 40 years of extensive experience in Power & Water Utilities and Other Energy Sectors. His expertise includes Electrical Safety, Power System Equipment, Electrical Drawing, Transmission Networks, Substation, Cable & Over Head Line, Substation Automation Systems & Application, Distribution Networks, Circuit Breaker, HV Switchgear Maintenance, HV/LV Electrical Authorisation, Basic Electricity, Electrical & Special Hazards, Personnel Protection, HV/LV Equipment, Motor Controllers, Electrical Switching Practices, Uninterruptible Power Supply (UPS), UPS and Battery System, Preventive Maintenance of Battery Charger and UPS System, UPS, DC System & Battery Design, Operation, Maintenance & Troubleshooting, Emergency Planning, Safety Management, Safety Instrumented Systems (SIS), Safety Integrity Level (SIL), Emergency Shutdown (ESD); Electrical Installation, Maintenance & Troubleshooting, Electrical Inspection & Testing, Electrical Measurements, Power Flow Analysis of Electrical Power Systems, Electrical Fundamentals, Basic Electricity & Electrical Codes, DCS, SCADA & PLC; Measurement (Flow, Temperature, Pressure); Process Analyzers & Analytical Instrumentation; Process Control, Instrumentation & Safeguarding; Process Controller, Control Loop & Valve Tuning; Industrial Distribution Systems; Industrial Control & Control Systems, Power Systems Protection & Relaying; Earthing, Bonding, Grounding, Lightning & Surge Protection; Electric Power Substation & Systems; Electrical Engineering Principles; Motor Control Circuit; Electrical Fault Analysis; Electrical Networks & Distribution Cables; Circuit Breakers, Switchgears, Transformers, Hazardous Areas Classification and Detailed Engineering Drawings, Codes & Standards. Furthermore, he is also well-versed in Microprocessors Structure, Lead Auditor (ISO 9000:2000), ISO 9002, Quality Assurance, and Projects & Contracts Management.

Presently, Mr. Marave is the **Technical Advisor of Chamber of Industry & Commerce** in Greece. Prior to this, he gained his thorough practical experience through several positions as the **Technical Instructor, Engineering Manager, Electronics & Instruments Head, Electrical, Electronics & Instruments Maintenance Superintendent, Assistant General Technical Manager and Engineering Supervisor** of various international companies such as the **Alumil Mylonas, Athens Papermill, Astropol** and the **Science Technical Education**.

Mr. Marave is a **Registered Professional Engineer** and has **Master and Bachelor** degrees in **Electrical Engineering** from the **Polytechnic Institute of New York and Pratt Institute of New York (USA)** respectively. Further, he is a **Certified Instructor/Trainer, a Certified Internal Verifier/Assessor/Trainer** by the **Institute of Leadership & Management (ILM)** and an active member of the **Technical Chamber** and the **Institute of Electrical and Electronics Engineer (IEEE)** in Greece. He has presented and delivered **numerous international** courses, conferences, trainings and workshops worldwide.

Training Methodology

All our Courses are including **Hands-on Practical Sessions** using equipment, State-of-the-Art Simulators, Drawings, Case Studies, Videos and Exercises. The courses include the following training methodologies as a percentage of the total tuition hours:-

- 30% Lectures
- 20% Practical Workshops & Work Presentations
- 30% Hands-on Practical Exercises & Case Studies
- 20% Simulators (Hardware & Software) & Videos

In an unlikely event, the course instructor may modify the above training methodology before or during the course for technical reasons.

Course Fee

US\$ 5,500 per Delegate + **VAT**. This rate includes H-STK® (Howard Smart Training Kit), buffet lunch, coffee/tea on arrival, morning & afternoon of each day

Accommodation

Accommodation is not included in the course fees. However, any accommodation required can be arranged at the time of booking

Course Program

The following program is planned for this course. However, the course instructor(s) may modify this program before or during the course for technical reasons with no prior notice to participants. Nevertheless, the course objectives will always be met:

Day 1: Sunday, 16th February 2025

0730 – 0800	Registration & Coffee
0800 – 0815	Welcome & Introduction
0815 – 0830	PRE-TEST
0830 – 0930	General Requirements Inspections
0930 – 0945	Break
0945 – 1045	Electrical & Instrument Document
1045 – 1200	Material Selection
1200 – 1215	Break
1215 – 1330	Installation
1330 – 1420	Safety Checklist for Electrical Inspections
1420 – 1430	Recap
1430	Lunch & End of Day One

Day 2: Monday, 17th February 2025

0730 – 0900	General Wiring Methods
0900 – 0915	Break
0915 – 1100	Boxes & Conduit Bodies
1100 – 1230	Cabinets & Cutout Boxes
1230 – 1245	Break
1245 – 1420	Switches & Receptacles
1420 – 1430	Recap
1430	Lunch & End of Day Two



Day 3: Tuesday, 18th February 2025

0730 – 0930	<i>Services, Feeders & Branch Circuits</i>
0930 – 0945	<i>Break</i>
0945 – 1100	<i>Grounding & Bonding</i>
1100 – 1215	<i>General Electrical Inspection Checklists</i>
1215 – 1230	<i>Break</i>
1230 – 1420	<i>Commercial and Industrial Inspections Motors • Transformers • Capacitors • Signs and Outline Lighting</i>
1420 – 1430	Recap
1430	<i>Lunch & End of Day Three</i>

Day 4: Wednesday, 19th February 2025

0730 – 0930	<i>Hazardous Locations Checklist Checklist of Class I Locations • Checklist of Class II Locations • Checklist of Class III Locations</i>
0930 – 0945	<i>Break</i>
0945 – 1100	<i>Instrument Controller</i>
1100 – 1215	<i>Piping & Instrument Diagram</i>
1215 – 1230	<i>Break</i>
1230 – 1420	<i>Fire & Gas Detection & ESD (Emergency Shutdown)</i>
1420 – 1430	Recap
1430	<i>Lunch & End of Day Four</i>

Day 5: Thursday, 20th February 2025

0730 – 0930	<i>Telecommunication</i>
0930 – 0945	<i>Break</i>
0945 – 1100	<i>Calibrate & Function Test Instrument</i>
1100 – 1200	<i>Hazardous Location</i>
1200 – 1215	<i>Break</i>
1215 – 1300	<i>Basic & Regulation Inspection</i>
1300 – 1315	Course Conclusion
1315 – 1415	COMPETENCY EXAM
1415 – 1430	<i>Presentation of Course Certificates</i>
1430	<i>Lunch & End of Course</i>

Simulators (Hands-on Practical Sessions)

Practical sessions will be organized during the course for delegates to practice the theory learnt. Delegates will be provided with an opportunity to carryout various exercises using our state-of-the-art simulators “Haward Troubleshooting”, “Power World”, “GE Multilin Relay 469” and “GE Multilin Relay 750”.

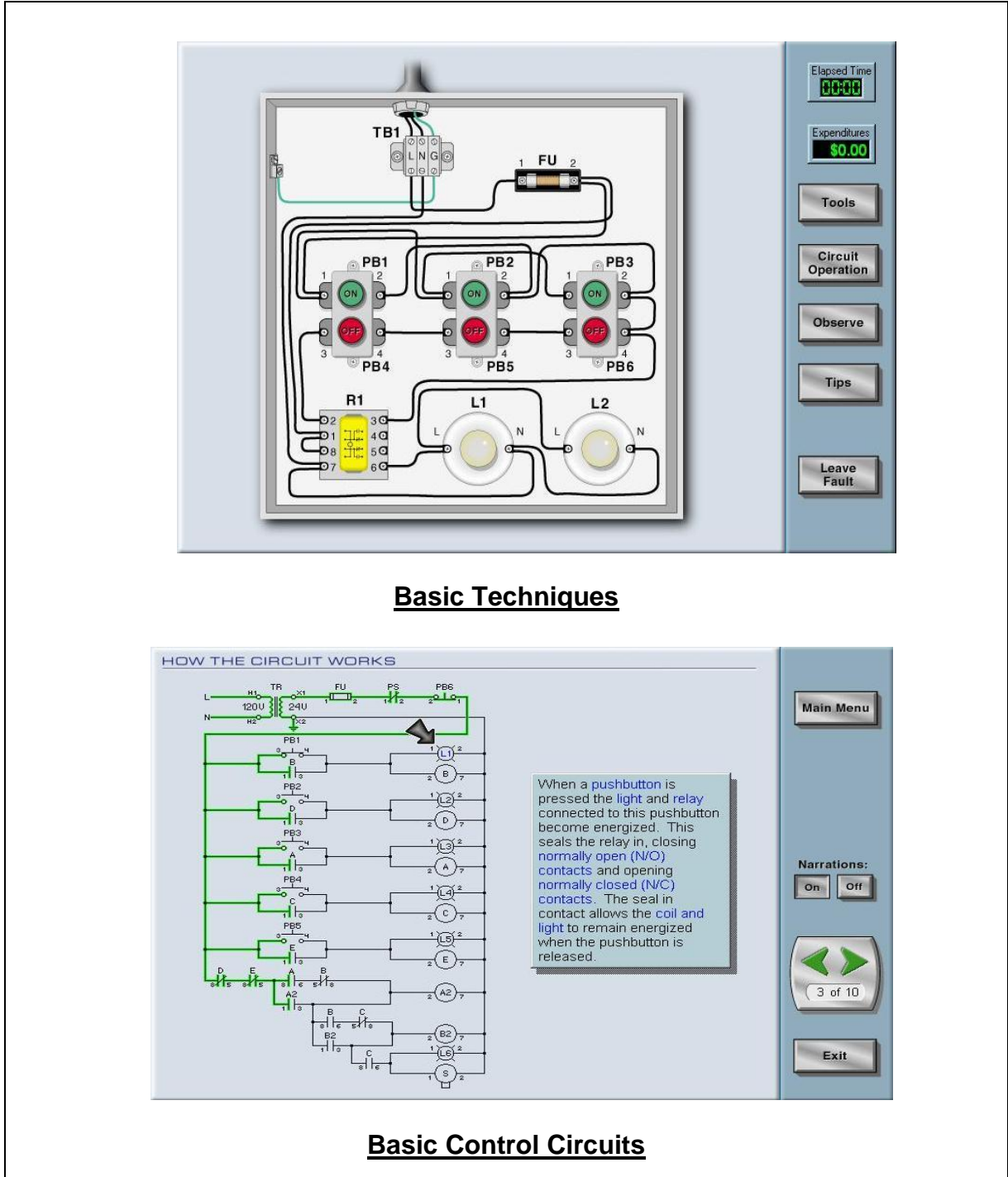

The simulator interface is divided into two main sections. The top section, titled "Basic Techniques", displays a physical representation of an electrical control panel. It includes a terminal block (TB1) with L, N, and G terminals, a fuse (FU), six pushbuttons (PB1-PB6) arranged in two columns of three, and two indicator lamps (L1 and L2). Each pushbutton has an "ON" (green) and "OFF" (red) indicator. The bottom section, titled "Basic Control Circuits", shows a schematic diagram of the circuit's internal wiring. It details the power supply (120V AC), the fuse, and the interlocking logic between the pushbuttons, a relay (R1), and the indicator lamps. A text box explains the latching mechanism: "When a pushbutton is pressed the light and relay connected to this pushbutton become energized. This seals the relay in, closing normally open (N/O) contacts and opening normally closed (N/C) contacts. The seal in contact allows the coil and light to remain energized when the pushbutton is released." The interface also features a sidebar with various controls like "Elapsed Time", "Expenditures", "Tools", "Circuit Operation", "Observe", "Tips", "Leave Fault", "Main Menu", "Narrations", and "Exit".

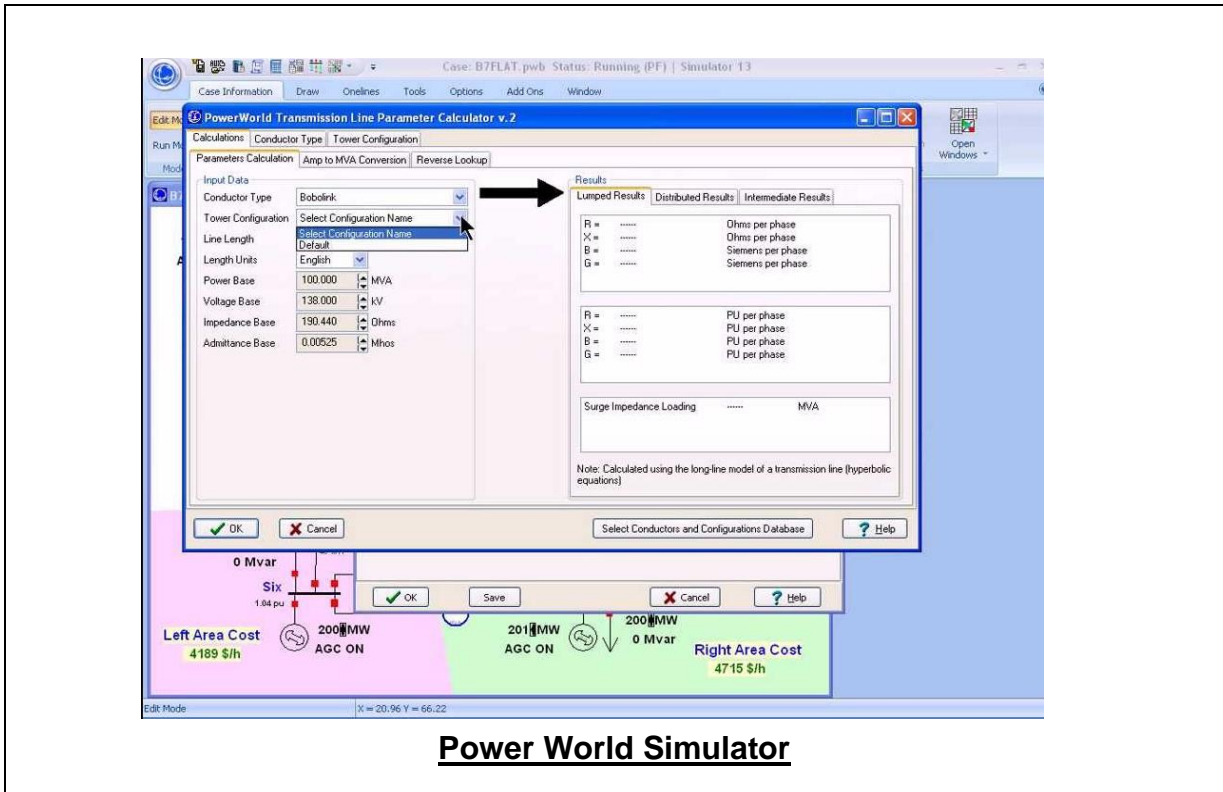
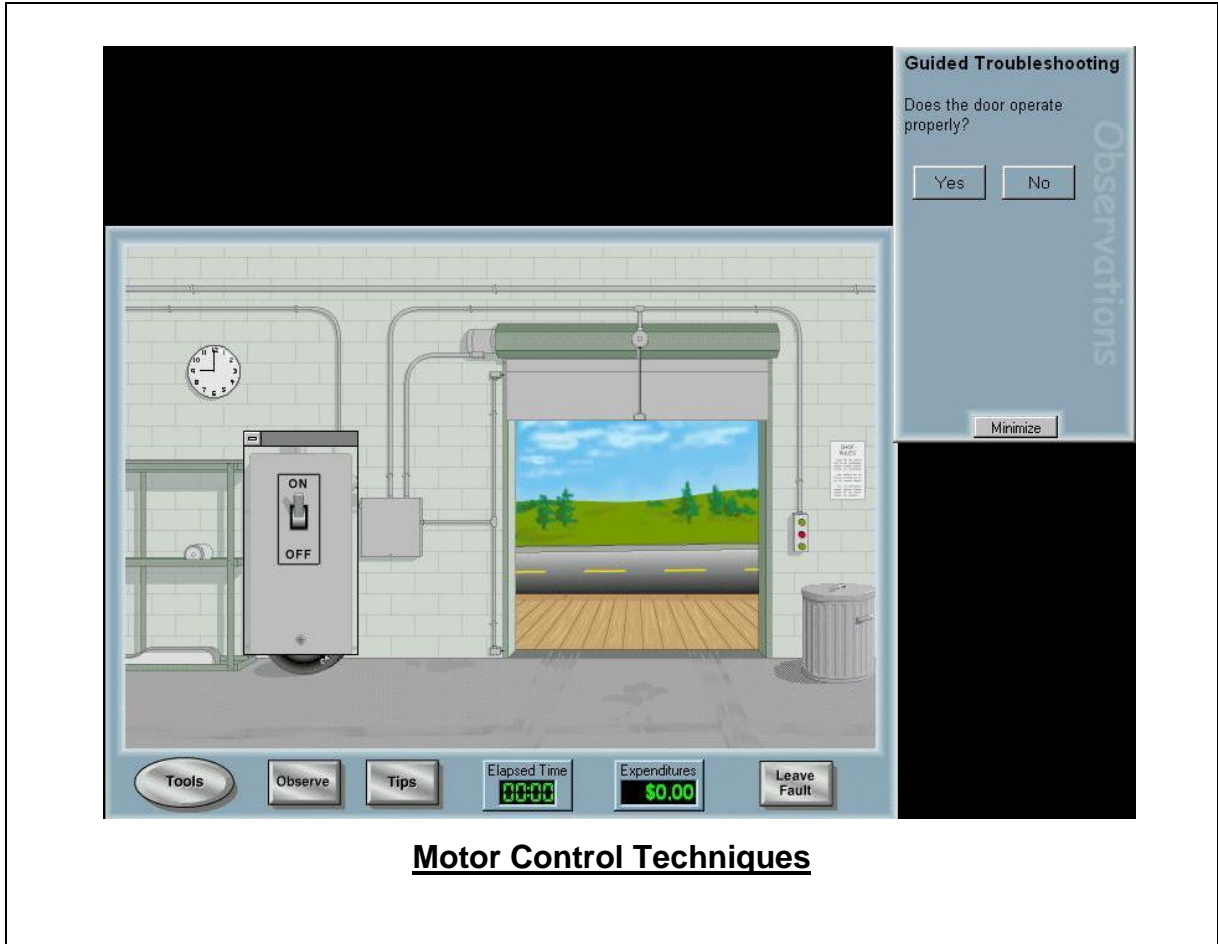



GE Multilin Relay 469 Simulator



GE Multilin Relay 750 Simulator

Course Coordinator

Mari Nakintu, Tel: +971 2 30 91 714, Email: mari1@haward.org

