



## COURSE OVERVIEW ME0530 HVAC Direct Digital Control (DDC)

### Course Title

HVAC Direct Digital Control (DDC)

### Course Date/Venue

October 21-24, 2024/Boardroom 1, Elite Byblos Hotel Al Barsha, Sheikh Zayed Road, Dubai, UAE

### Course Reference

ME0530

### Course Duration/Credits

Four days/2.4 CEUs/24 PDHs



### Course Description



***This practical and highly-interactive course includes practical sessions and exercises. Theory learnt will be applied using our state-of-the-art simulators.***

**(1) Industrial Facility Visit:** Course participants will be taken to an industrial facility where they will practice testing, maintenance and troubleshooting. In case that this course is organized inside client premises (In-House), then client shall provide access to its HVAC and refrigeration workshop for practical sessions.



**(2) HVAC Simulator:** Participants will use in the class the state-of-the-art HVAC Simulator to practice some of the skills learnt.

Over the last 20 years, no one area of the HVAC industry has changed so dramatically as controls. These critical HVAC subsystems have undergone significant and fundamental changes, perhaps the most drastic of any in our industry. We have evolved from pneumatic controls to "overlay" energy management systems and first generation Direct Digital Controls (DDC), to current generation distributed DDC. The transition has been rapid and today we find ourselves dealing with control systems that are very different than those that were available just a few years ago.



The computer industry's trend of increasing processing power and memory at a lower cost over time is quickly influencing DDC controllers. The advent of open protocols and increased availability and use of site/building/campus networks has increased the complexity of the design, procurement, and operations of these systems. Twenty years ago, we were looking at pneumatic receiver controllers, transmitters, and actuators, along with first-generation, expensive, and centralized DDC products.





Today, our control systems are graphical, decentralized, relatively inexpensive, and serve up information to us via the Internet. We have moved from a non-proprietary communication protocol that relied on air pressure, to a very proprietary one that allows us to receive and respond to control alarms via our cell phones. Additionally, the control logic that in the past was distributed to single-function hardware components (receiver controllers, switching relays, etc.) now resides in software.

The DDC system is the "brain" of the HVAC system. It dictates the position of every damper and valve, along with which fans, pumps, and chillers run, and at what speed or capacity. Yet, proportionally, it receives very little consideration as compared to the rest of the system during the design phase. This applies in the procurement, installation and maintenance phases as well. Therefore, this course is designed to improve the participant's knowledge of current DDC systems and the issues surrounding their correct deployment into HVAC systems. The course will give participant a broad range of knowledge to understand the principles and technical concepts used by the various manufacturers. This understanding is essential for the acquisition, implementation, and operation of a cost-effective system. The course will also cover planning, designing and specifying DDC systems. It will provide participant with a comprehensive understanding of the technologies available today.

### **Course Objectives**

This intensive and interactive course is your opportunity to expand your knowledge of direct digital control systems (DDC) for control of HVAC processes. This course will enable you to:-

- Define your requirements for a DDC system to serve HVAC and related building systems
- Describe the hardware and software elements that make up a DDC system
- Develop a DDC architectural master plan for your requirements
- Describe the essential elements of a DDC system specification
- Define the application requirements for the building systems
- Plan for the commissioning of the DDC system
- Determine how to design HVAC DDC Systems
- Identify the various types of commonly used control systems
- Review open DDC systems that allow for future expansion and interoperability
- Recognize the Internet DDC system
- Use the WEB-Browser for Automation Interface
- Apply the critical do's and don'ts as well as accepted rule-of-thumb checks in HVAC control design





### Exclusive Smart Training Kit - H-STK®



Participants of this course will receive the exclusive “Haward Smart Training Kit” (H-STK®). The H-STK® consists of a comprehensive set of technical content which includes **electronic version** of the course materials, sample video clips of the instructor’s actual lectures & practical sessions during the course conveniently saved in a **Tablet PC**.

### Who Should Attend

This course provides an overview of all significant aspects and considerations of HVAC direct digital control (DDC) for consulting, design, and energy engineers, commissioning authorities, applications engineers, plant engineers, architects and planning technical staff responsible for the design, acquisition or operation of environmental control systems in commercial, institutional or industrial facilities. You will design, specify and estimate costs for DDC system. The course is recommended for those interested in or involved with HVAC DDC systems, including mechanical engineers, HVAC designers, building engineers, facility engineers, utility engineers, HVAC contractors, manufacturers representatives, other technical staff and recent college graduates in engineering.

### Training Methodology

All our Courses are including **Hands-on Practical Sessions** using equipment, State-of-the-Art Simulators, Drawings, Case Studies, Videos and Exercises. The courses include the following training methodologies as a percentage of the total tuition hours:-

- 30% Lectures
- 20% Practical Workshops & Work Presentations
- 30% Hands-on Practical Exercises & Case Studies
- 20% Simulators (Hardware & Software) & Videos

In an unlikely event, the course instructor may modify the above training methodology before or during the course for technical reasons.

### Accommodation

Accommodation is not included in the course fees. However, any accommodation required can be arranged at the time of booking.

### Course Fee

**US\$ 4,500** per Delegate + **VAT**. This rate includes H-STK® (Haward Smart Training Kit), buffet lunch, coffee/tea on arrival, morning & afternoon of each day.



**Course Certificate(s)**

Internationally recognized certificates will be issued to all participants of the course who completed a minimum of 80% of the total tuition hours.

**Certificate Accreditations**

Certificates are accredited by the following international accreditation organizations:-

-  The International Accreditors for Continuing Education and Training (IACET - USA)

Haward Technology is an Authorized Training Provider by the International Accreditors for Continuing Education and Training (IACET), 2201 Cooperative Way, Suite 600, Herndon, VA 20171, USA. In obtaining this authority, Haward Technology has demonstrated that it complies with the **ANSI/IACET 2018-1 Standard** which is widely recognized as the standard of good practice internationally. As a result of our Authorized Provider membership status, Haward Technology is authorized to offer IACET CEUs for its programs that qualify under the **ANSI/IACET 2018-1 Standard**.

Haward Technology’s courses meet the professional certification and continuing education requirements for participants seeking **Continuing Education Units (CEUs)** in accordance with the rules & regulations of the International Accreditors for Continuing Education & Training (IACET). IACET is an international authority that evaluates programs according to strict, research-based criteria and guidelines. The CEU is an internationally accepted uniform unit of measurement in qualified courses of continuing education.

Haward Technology Middle East will award **2.4 CEUs** (Continuing Education Units) or **24 PDHs** (Professional Development Hours) for participants who completed the total tuition hours of this program. One CEU is equivalent to ten Professional Development Hours (PDHs) or ten contact hours of the participation in and completion of Haward Technology programs. A permanent record of a participant’s involvement and awarding of CEU will be maintained by Haward Technology. Haward Technology will provide a copy of the participant’s CEU and PDH Transcript of Records upon request.

-  British Accreditation Council (BAC)

Haward Technology is accredited by the **British Accreditation Council** for **Independent Further and Higher Education** as an **International Centre**. BAC is the British accrediting body responsible for setting standards within independent further and higher education sector in the UK and overseas. As a BAC-accredited international centre, Haward Technology meets all of the international higher education criteria and standards set by BAC.





### Course Instructor(s)

This course will be conducted by the following instructor(s). However, we have the right to change the course instructor(s) prior to the course date and inform participants accordingly:



**Mr. Peter Wyk, MSc, BSc, is a Senior Engineer with over 35 years of extensive experience. His Expertise extends over the areas of Modern Heating, Ventilation, Air-Conditioning (HVAC) & Refrigeration Systems, Air Conditioning System, HVAC Direct Digital Control (DDC), Electric Arc Furnace (EAF) Operations, Air Cooler Design; Chillers; Mass & Heat Transfer, Electromechanical, Rotating & Static Equipment, HVAC System, HVAC Maintenance, Electric Arc Furnace (EAF) Operations, Vacuum Arc Degasser, RH Degasser, Arc Furnace Steelmaking,**

**Ladle Furnace, Continuous Casting Operation, Hot Rolling Process, Hot Strip Mill, Mill Operations, Roll Mill, Steel Making Process, Steel Manufacturing, Electric Arc Furnace (EAF), Steel Forging, Steel Manufacturing & Process Troubleshooting, Slit Rolling, Carbon Steel Pipe Wall Thickness & Grade Selection, Ferro-Alloys, Steel Metallurgy, Steel Structure Welding, Steelmaking Slag, Steel Making Application, Electric Steelmaking, Steel Manufacturing & Commissioning, Consteel Scrap Feeding System, Steel Manufacturing for Off-shore Applications, Iron & Steel Making Technology, Steel Forging, Heat Treatment & Prevention Techniques, Corrosion Fabrication & Inspection and Post Weld Heat Treatment, Welding Inspection, Welding & Machine Techniques, TIG & Arc Welding, Shielded Metal Arc Welding, Gas Tungsten & Gas Metal Arc Welding, Welding Procedure Specifications & Qualifications, Aluminium Welding, Hot Work-Safety, SMAW, GTAW, Welding Techniques, Pipeline Welding Practices, Welding Engineering, Welding Fatigue & Fracture Mechanics, Welding Inspection Technology, Welding Safety, Welding Defects Analysis, Welding Technology, Welding Problems, Welding & Non Destructive Testing and Metallurgy Techniques, Metallurgy, Pyro-Metallurgy, VAD Process, Fuels & Combustion, GE Gas Turbine (MS6001 B) Cycle & Major Components, Oil Systems of GE Gas Turbine Units, Fuel Gas Conditioning and Control, Fuel Systems of GE Gas Turbine Units, Cooling Water System in Power Plant and Compressed Air System in Power Plant. Further, he is also well-versed in Heat Transfer, Desulphurisation & Nitrogen Pick-up, Rod Production, Strength of Material, Oxy-fuel Burners and Carbon Injectors. Currently, he is the Director of Wire-n-Plier Technologies that provides consultancy services for arc furnace, steel making, steel production and metallurgy for multiple manufacturing firms.**

During Mr. Wyk's long career life, he has gained his technical and practical expertise through various challenging and key positions such as the **Senior Project Manager, General Manager Operations, Meltshop Manager, Superintendent Steelmaking, Trainee Manager, Metallurgical Engineer, Trainee Engineer** and **Lecturer** for several international companies and universities such as the **Gulf Speciality Steel Industries, Vaal University of Technology, Cape Gate Davsteel Division – Meltshop** and **ISCOR** just to name a few.

Mr. Wyk has a **Master's** degree in **Engineering Management** from the **University of Pretoria** and a **Bachelor's** degree in **Metallurgy Engineering** from the **University of Potchefstroom**. He has also presented numerous papers and international conferences including the **7<sup>th</sup> European Electric Steelmaking Conference** in Venice, Italy. Further, he is a **Certified Instructor/Trainer** and has delivered various trainings, workshops, seminars, courses and conferences internationally.



**Course Program**

The following program is planned for this course. However, the course instructor(s) may modify this program before or during the course for technical reasons with no prior notice to participants. Nevertheless, the course objectives will always be met:

**Day 1: Monday 21<sup>th</sup> of October 2024**

0730 - 0800	Registration & Coffee
0800 - 0815	Welcome & Introduction
0815 - 0830	<b>PRE-TEST</b>
0830 - 0930	<b>Overview of Artificial Lift Technology</b>

0930 - 0945	Break
0945 - 1100	<b>Introduction for IPR &amp; Artificial Lift Types</b>
1100 - 1230	<b>Criteria for Selection of Artificial Lift System</b>
1230 - 1245	Break
1245 - 1420	<b>Reservoir Performance: Inflow &amp; Outflow Relationships</b>
1420 - 1430	<b>Recap</b>
1430	Lunch & End of Day One

**Day 2: Tuesday 22<sup>th</sup> of October 2024**

0730 - 0930	<b>Natural Flow</b>
0930 - 0945	Break
0945 - 1100	<b>Inflow Performance</b>
1100 - 1230	<b>Tubing Flow Performance</b>
1230 - 1245	Break
1245 - 1420	<b>Well Performance</b>
1420 - 1430	<b>Recap</b>
1430	Lunch & End of Day Two

**Day 3: Wednesday 23<sup>th</sup> of October 2024**

0730 - 0930	<b>Artificial Lift Screening</b>
0930 - 0945	Break
0945 - 1100	<b>Introduction for PCP, SRP &amp; ESP Equipments &amp; Design Data &amp; Process</b>
1100 - 1230	<b>Rod-Pump Design: Pumping Unit, Rods, Pump, Prime Movers, Gas Anchor, Pump-off Controls</b>
1230 - 1245	Break
1245 - 1420	<b>Application of Gas Lift Technology &amp; its Limitations</b>
1420 - 1430	<b>Recap</b>
1430	Lunch & End of Day Three



**Day 4: Thursday 24<sup>th</sup> of October 2024**

0730 – 0830	<i>Gas Lift Design: Mandrels, Valves, Injection Gas Requirements, Temperature, Chokes, Spacing, Equilibrium Curve, Continuous Flow Design</i>
0830 – 0930	<i>ESP Design: Pump Performance Curves, Pump Intake Curves, Typical Problems, Installation, Troubleshooting</i>
0930 – 0945	<i>Break</i>
0945 – 1230	<i>ESP Design: Pump Performance Curves, Pump Intake Curves, Typical Problems, Installation, Troubleshooting (cont'd)</i>
1230 – 1245	<i>Break</i>
1245 – 1330	<i>Optimization Methods for PCP, SRP &amp; ESP Using Nodal Analysis Software</i>
1330 – 1400	<i>Course Conclusion</i>
1400 – 1415	<b>POST-TEST</b>
1415 – 1430	<i>Presentation of Course Certificates</i>
1430	<i>Lunch &amp; End of Course</i>



**Practical Sessions/Site Visit**







**Simulator (Hands-on Practical Sessions)**

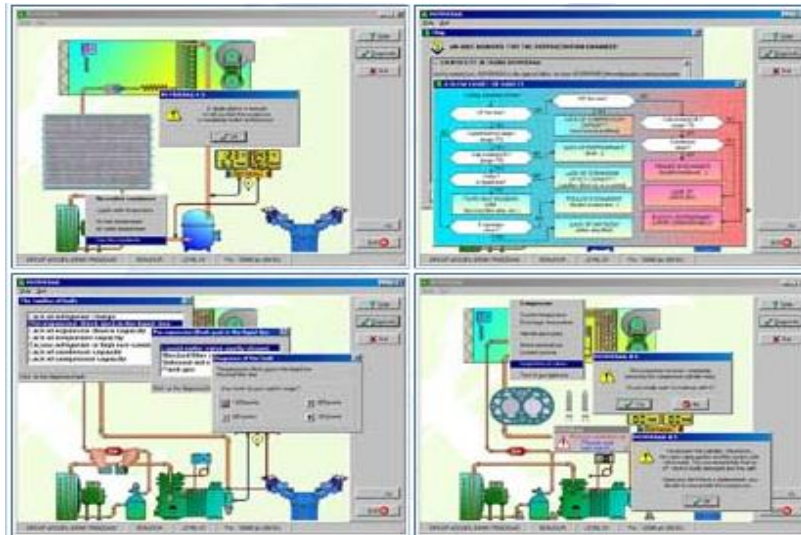

**KOTZA HVAC Simulator**

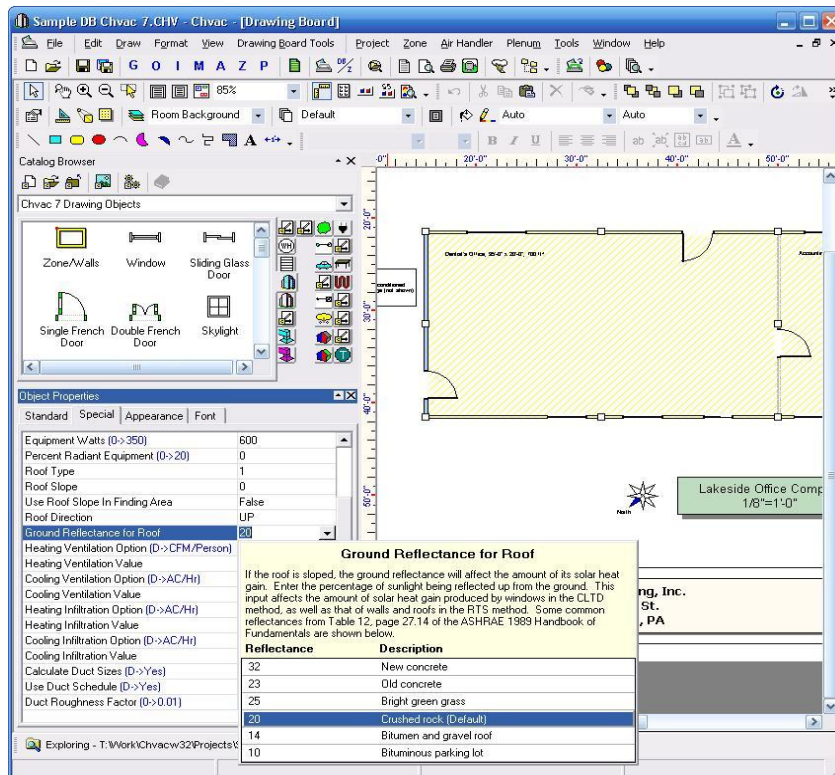

**Elite CHVAC Simulator**

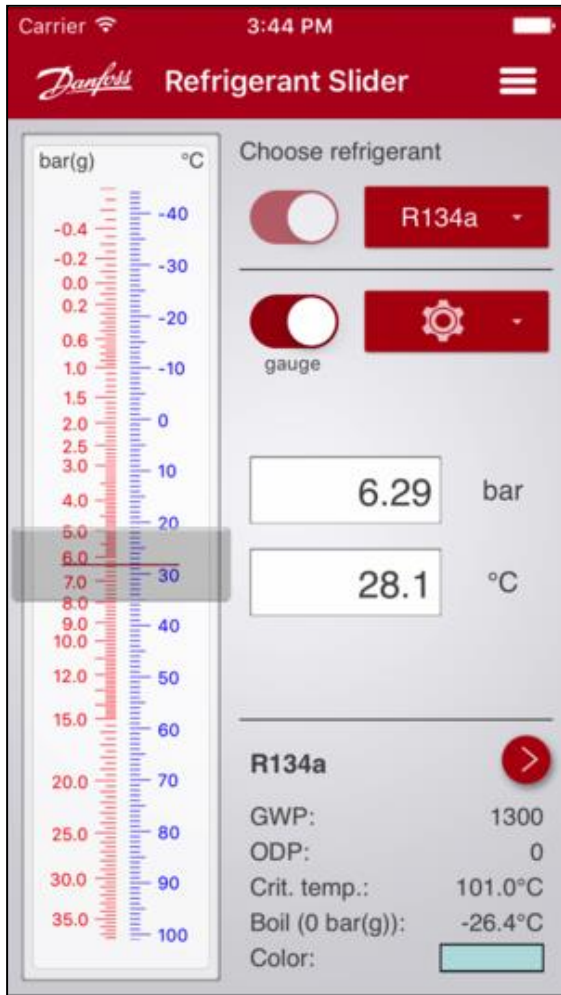

Danfoss Refrigerant Slider App

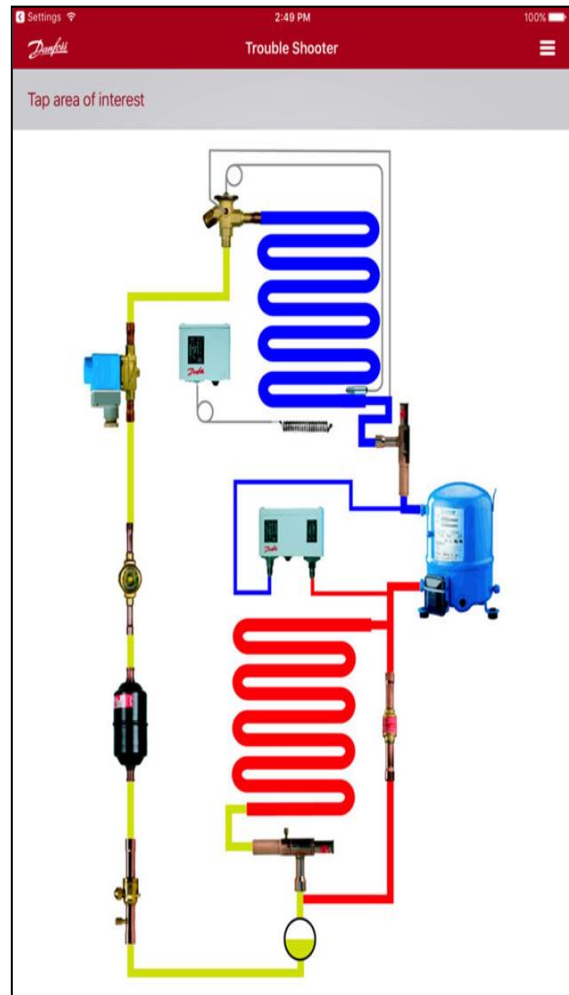

Danfoss Troubleshooter App

**Course Coordinator**

Mari Nakintu, Tel: +971 2 30 91 714, Email: [mari1@haward.org](mailto:mari1@haward.org)