

COURSE OVERVIEW ME0138
Application of Standards in Boiler, Pressure Vessel & Piping Systems

Course Title

Application of Standards in Boiler, Pressure Vessel & Piping Systems

Course Reference

ME0138

Course Duration/Credits

Five days/3.0 CEUs/30 PDHs



Course Date/Venue

Session(s)	Date	Venue
1	May 25-29, 2025	Meeting Plus 9, City Centre Rotana, Doha Qatar
2	July 21-25, 2025	Glasshouse Meeting Room, Grand Millennium Al Wahda Hotel, Abu Dhabi, UAE
3	August 24-28, 2025	Safir Meeting Room, Divan Istanbul, Turkey
4	November 23-27, 2025	Boardroom 1, Elite Byblos Hotel Al Barsha, Sheikh Zayed Road, Dubai, UAE
5	January 11-15, 2026	Boardroom 1, Elite Byblos Hotel Al Barsha, Sheikh Zayed Road, Dubai, UAE
6	February 08-12, 2026	Olivine Meeting Room, Fairmont Nile City, Cairo, Egypt

Course Description



This practical and highly-interactive course includes various practical sessions and exercises. Theory learnt will be applied using our state-of-the-art simulators.



This course is intended to introduce codes for construction such as ASME boiler and pressure vessel code and ASME piping codes. It will show the similarities and differences between codes and how standards such as B16, MSS, ASTM, and ISO fit into the various codes.



The course will also demonstrate how the different methods of pressure rating of components are used. The course participants will work examples using the four major methods. These methods are pressure rating by table, schedule, proof testing, and computation. The course will give examples of how to work both with components fully complying and with deviations to fit specific cases.

During this interactive course, participants will learn the differences between different standards rating organizations; the history behind various product standards; the appropriate needed product standard; the pressure temperature rating tables; the class rating systems and the method of proof testing; and the proof test documentation and comparison method of pressure rating.

Course Objectives

Upon the successful completion of this course, each participant will be able to:-

- Apply and gain an in-depth knowledge on the application of standards in boiler, pressure vessel and piping systems
- Determine which code applies to their projects and which standards fit each code
- Relate the differences between different standards rating organizations
- Discuss the history behind various product standards
- Specify the appropriate needed product standard
- Illustrate pressure temperature rating tables
- Use class rating systems and apply the method of proof testing
- Evaluate proof test documentation and the comparison method of pressure rating
- Develop and use “unlisted components” and distinguish the fatigue decisions as compared to pressure design
- Compute pressure ratings efficiently

Exclusive Smart Training Kit - H-STK®



Participants of this course will receive the exclusive “Howard Smart Training Kit” (H-STK®). The H-STK® consists of a comprehensive set of technical content which includes **electronic version** of the course materials conveniently saved in a **Tablet PC**.

Who Should Attend

This course provides an overview of all significant aspects and considerations on the design, fabrication, inspection and repair of oil and gas pipeline code in accordance with the international standard ASME B31.4-B31.8 for those who are involved in engineering or technical aspects of pipelines, including designers, engineers, engineering managers, construction supervisors, operations supervisors, inspectors, code compliance managers, asset integrity managers, pipeline safety regulators, consultants and other technical staff. Further, the course is also suitable for those new to pipelines, as well as providing a good refresher for experienced personnel.

Accommodation

Accommodation is not included in the course fees. However, any accommodation required can be arranged at the time of booking.

Course Certificate(s)

Internationally recognized certificates will be issued to all participants of the course who completed a minimum of 80% of the total tuition hours.

Certificate Accreditations

Certificates are accredited by the following international accreditation organizations:-

- 

British Accreditation Council (BAC)

Haward Technology is accredited by the **British Accreditation Council** for **Independent Further and Higher Education** as an **International Centre**. BAC is the British accrediting body responsible for setting standards within independent further and higher education sector in the UK and overseas. As a BAC-accredited international centre, Haward Technology meets all of the international higher education criteria and standards set by BAC.

- 

The International Accreditors for Continuing Education and Training (IACET - USA)

Haward Technology is an Authorized Training Provider by the International Accreditors for Continuing Education and Training (IACET), 2201 Cooperative Way, Suite 600, Herndon, VA 20171, USA. In obtaining this authority, Haward Technology has demonstrated that it complies with the **ANSI/IACET 2018-1 Standard** which is widely recognized as the standard of good practice internationally. As a result of our Authorized Provider membership status, Haward Technology is authorized to offer IACET CEUs for its programs that qualify under the **ANSI/IACET 2018-1 Standard**.

Haward Technology’s courses meet the professional certification and continuing education requirements for participants seeking **Continuing Education Units** (CEUs) in accordance with the rules & regulations of the International Accreditors for Continuing Education & Training (IACET). IACET is an international authority that evaluates programs according to strict, research-based criteria and guidelines. The CEU is an internationally accepted uniform unit of measurement in qualified courses of continuing education.

Haward Technology Middle East will award **3.0 CEUs** (Continuing Education Units) or **30 PDHs** (Professional Development Hours) for participants who completed the total tuition hours of this program. One CEU is equivalent to ten Professional Development Hours (PDHs) or ten contact hours of the participation in and completion of Haward Technology programs. A permanent record of a participant’s involvement and awarding of CEU will be maintained by Haward Technology. Haward Technology will provide a copy of the participant’s CEU and PDH Transcript of Records upon request.



Course Instructor(s)

This course will be conducted by the following instructor(s). However, we have the right to change the course instructor(s) prior to the course date and inform participants accordingly:



Mr. Karl Thanasis, PEng, MSc, MBA, BSc, is **Senior Mechanical & Maintenance Engineer** with over **30 years** of extensive industrial experience. His wide expertise includes **Piping & Pipeline**, Maintenance, Repair, **Shutdown, Turnaround & Outages**, **Maintenance & Reliability** Management, **Mechanical Maintenance** Planning, Scheduling & Work Control, Advanced Techniques in **Maintenance** Management, **Predictive & Preventive** Maintenance, **Maintenance & Operation Cost Reduction** Techniques, Reliability

Centered Maintenance (RCM), **Machinery Failure Analysis**, **Rotating Equipment Reliability** Optimization & Continuous Improvement, **Material Cataloguing**, **Mechanical & Rotating Equipment** Troubleshooting & Maintenance, **Root Cause Analysis & Reliability** Improvement, **Condition** Monitoring, **Root Cause Failure Analysis (RCFA)**, **Steam Generation**, **Steam Turbines**, **Power Generator Plants**, **Gas Turbines**, **Combined Cycle Plants**, **Boilers**, **Process Fired Heaters**, Air Preheaters, Induced Draft Fans, All Heaters Piping Work, Refractory Casting, Heater Fabrication, Thermal & Fired Heater Design, **Heat Exchangers**, Heat Transfer, Coolers, **Power Plant** Performance, Efficiency & Optimization, **Storage Tank** Design & Fabrication, **Thermal Power Plant** Management, **Boiler & Steam** System Management, **Pump** Operation & Maintenance, **Chiller & Chiller Plant** Design & Installation, **Pressure Vessel**, **Safety Relief Valve** Sizing & Selection, **Valve** Disassembling & Repair, Pressure Relief Devices (PSV), **Hydraulic & Pneumatic** Maintenance, Advanced **Valve** Technology, **Pressure Vessel** Design & Fabrication, **Pumps**, Turbo-Generator, Turbine **Shaft Alignment**, **Lubrication**, Mechanical **Seals**, Packing, **Blowers**, **Bearing** Installation, **Couplings**, **Clutches** and **Gears**. Further, he is also versed in **Wastewater Treatment** Technology, **Networking** System, **Water Network Design**, Industrial **Water Treatment** in Refineries & Petrochemical Plants, **Piping** System, Water Movement, Water Filtering, Mud Pumping, **Sludge Treatment** and **Drying**, **Aerobic Process** of **Water Treatment** that includes **Aeration**, **Sedimentation** and **Chlorination** Tanks. His strong background also includes **Design** and **Sizing** of all **Waste Water Treatment Plant Associated Equipment** such as **Sludge Pumps**, **Filters**, **Metering Pumps**, **Aerators** and **Sludge Decanters**.

Mr. Thanasis has acquired his thorough and practical experience as the **Project Manager**, **Plant Manager**, **Area Manager - Equipment Construction**, **Construction Superintendent**, **Project Engineer** and **Design Engineer**. His duties covered **Plant Preliminary Design**, **Plant Operation**, **Write-up of Capital Proposal**, **Investment Approval**, **Bid Evaluation**, **Technical Contract Write-up**, **Construction** and **Sub-contractor Follow up**, **Lab Analysis**, **Sludge Drying** and **Management of Sludge Odor** and **Removal**. He has worked in various companies worldwide in the **USA**, **Germany**, **England** and **Greece**.

Mr. Thanasis is a **Registered Professional Engineer** in the **USA** and **Greece** and has a **Master** and **Bachelor** degrees in **Mechanical Engineering** with **Honours** from the **Purdue University** and **SIU** in **USA** respectively as well as an **MBA** from the **University of Phoenix** in **USA**. Further, he is a **Certified Internal Verifier/Trainer/Assessor** by the **Institute of Leadership & Management (ILM)** a **Certified Instructor/Trainer** and has delivered numerous trainings, courses, seminars, workshops and conferences worldwide.



Training Methodology

All our Courses are including **Hands-on Practical Sessions** using equipment, State-of-the-Art Simulators, Drawings, Case Studies, Videos and Exercises. The courses include the following training methodologies as a percentage of the total tuition hours:-

- 30% Lectures
- 20% Practical Workshops & Work Presentations
- 30% Hands-on Practical Exercises & Case Studies
- 20% Simulators (Hardware & Software) & Videos

In an unlikely event, the course instructor may modify the above training methodology before or during the course for technical reasons.

Course Fee

Doha	US\$ 6,000 per Delegate. This rate includes H-STK® (Haward Smart Training Kit), buffet lunch, coffee/tea on arrival, morning & afternoon of each day.
Abu Dhabi	US\$ 5,500 per Delegate + VAT . This rate includes H-STK® (Haward Smart Training Kit), buffet lunch, coffee/tea on arrival, morning & afternoon of each day.
Istanbul	US\$ 6,000 per Delegate + VAT . This rate includes Participants Pack (Folder, Manual, Hand-outs, etc.), buffet lunch, coffee/tea on arrival, morning & afternoon of each day.
Dubai	US\$ 5,500 per Delegate + VAT . This rate includes H-STK® (Haward Smart Training Kit), buffet lunch, coffee/tea on arrival, morning & afternoon of each day.
Cairo	US\$ 5,500 per Delegate + VAT . This rate includes H-STK® (Haward Smart Training Kit), buffet lunch, coffee/tea on arrival, morning & afternoon of each day.

Course Program

The following program is planned for this course. However, the course instructor(s) may modify this program before or during the course for technical reasons with no prior notice to participants. Nevertheless, the course objectives will always be met:

Day 1

0730 – 0800	<i>Registration & Coffee</i>
0800 – 0815	<i>Welcome & Introduction</i>
0815 – 0830	PRE-TEST
0830 – 0930	Introduction <i>Fundamentals and History of Codes and Standards Development of Standards and Codes</i>
0930 – 0945	<i>Break</i>
0945 – 1130	Pressure Design Basics <i>Review of Different Methods (Formulae) of Different Codes Including Workshop in the Use of and Differences of those Methods Including Rationale</i>
1130 – 1230	Review of Other Concerns in Codes & Standards Requirements <i>Fatigue Design Requirements, Material Selection Including the Differences Between SA and a Designations, Fabrication and Examination Requirements</i>

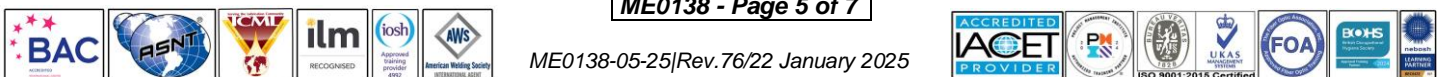



1230 – 1245	Break
1245 – 1420	Listed Vs. Unlisted Components How and Why the Various Codes List their Acceptable Standards
1420 – 1430	Recap
1430	Lunch & End of Day One

Day 2

0730 – 0930	Pressure Rating What it is and What it Means. How it May Vary With Process Conditions
0930 – 0945	Break
0945 – 1100	Overview of the Various Rating Methods Tables • Testing • Comparison • Computation
1100 – 1230	Tables How they are Developed, Reading, Interpolating
1230 – 1245	Break
1245 – 1420	Testing Types • Weaknesses, Strengths, Workshops
1420 – 1430	Recap
1430	Lunch & End of Day Two

Day 3

0730 – 0930	Workshops
0930 – 0945	Break
0945 – 1100	By Comparison Method B16.11
1100 – 1230	Computational Methods Unlisted Components
1230 – 1245	Break
1245 – 1420	Workshop in Computation
1420 – 1430	Recap
1430	Lunch & End of Day Three

Day 4

0730 – 0930	Review of Various Standards B16 • MSS • PFS
0930 – 0945	Break
0945 – 1100	General Standards Thread • Straight • Taper Threads
1100 – 1230	General Standards (cont'd) Thread • Straight • Taper Threads (cont'd)
1230 – 1245	Break
1245 – 1420	Picking the Proper Standard B16.5, B16.47 MSS Sp 44 Sp 51 for Example
1420 – 1430	Recap
1430	Lunch & End of Day Four

Day 5

0730 – 0930	Special Fittings
0930 – 0945	Break
0945 – 1100	Special Flanges
1100 – 1230	Review of What is Happening in Standards
1230 – 1245	Break

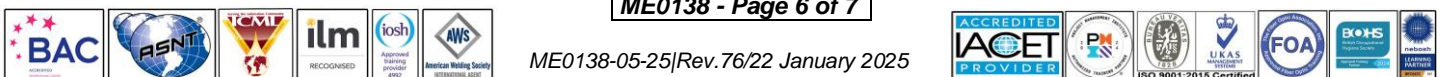



1245 – 1345	Open Forum
1345 – 1400	Course Conclusion
1400 – 1415	POST-TEST
1415 – 1430	<i>Presentation of Course Certificates</i>
1430	<i>Lunch & End of Course</i>

Simulator (Hands-on Practical Sessions)

Practical session will be organized during the course for delegates to practice the theory learnt. Delegates will be provided with an opportunity to carryout various exercises using the simulator “Win Boiler Sim” and “COMPRESS”.

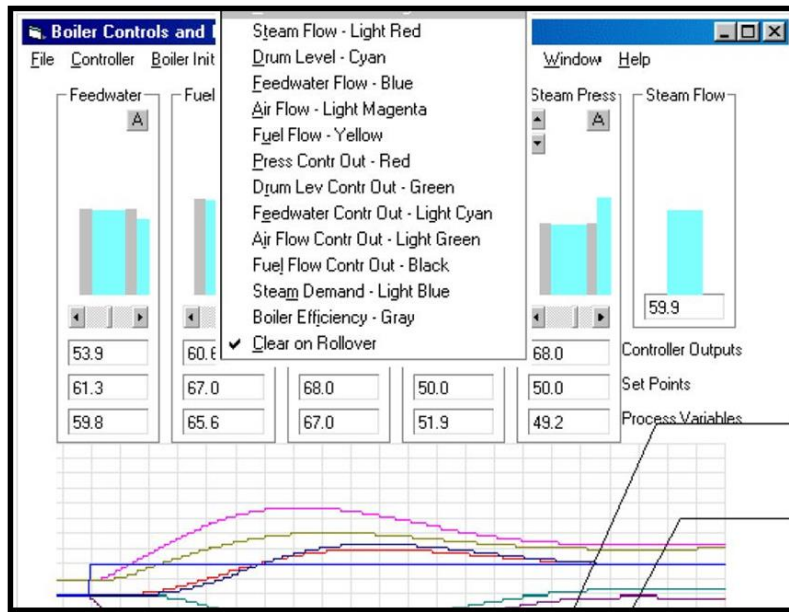

Win Boiler Sim

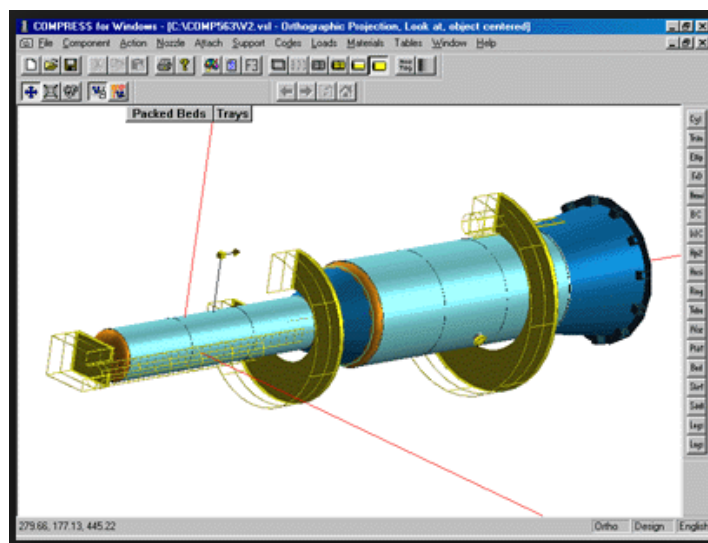

COMPRESS Simulator

Course Coordinator

Reem Dergham, Tel: +974 4423 1327, Email: reem@haward.org

