

**COURSE OVERVIEW ME0046**  
**Design, Analysis & Fabrication of Pressure Vessels**  
**(ASME Code Section VIII, Division 2)**

**Course Title**

Design, Analysis & Fabrication of Pressure Vessels (ASME Code Section VIII, Division 2)

**Course Date/Venue**

June 22-26, 2025/TBA Meeting Room, Taksim Square Hotel, Istanbul, Turkey

**Course Reference**

ME0046

**Course Duration/Credits**

Five days/3.0 CEUs/30 PDHs



**Course Description**



***This practical and highly-interactive course includes various practical sessions and exercises. Theory learnt will be applied using our state-of-the-art simulators.***



This course introduces participants to the design, analysis, and fabrication of pressure vessels fabricated as per the ASME Section VIII, Division 2 Code. It concentrates on those topics which are relevant to proper operation and maintenance of vessels after they have been placed in service. The course will emphasize on the design, inspection, examination and testing, as well as the proper assessment of inspection results for efficient and effective repairs; inspection rules of ASME Section VIII, Division 2 Code; example calculations used to depict the use of ASME Code in design; and assessment of repairs and modifications.



The course will also differentiate Division 1 and Division 2 of ASME Section VIII and discuss the theories of failure and design margins of various codes; the general requirements of ASME VIII, Division 2 and the responsibilities of various parties; the material requirements as well as material toughness and impact testing requirements; the design rules for internal pressure, buckling, formed and flat head and new method for design of openings and external loadings.



At the completion of the course, participants will be able to employ stress analysis methods and acceptance criteria for design analysis; classify stress and linearization as well as fatigue analysis and its exemption rules; simplify elastic-plastic analysis and list the various requirements for fabrication, PWHT, tolerances and NDE requirements; perform pressure testing, documentation and stamping; and identify the pressure requirements and example problems.

### **Course Objectives**

Upon the successful completion of this course, participants will be able to:

- Apply and gain a comprehensive knowledge on pressure vessels design, analysis and fabrication based on the ASME Code, Section VIII, Division 2
- Differentiate Division 1 and Division 2 of ASME Section VIII and discuss the theories of failure and design margins of various codes
- Identify the general requirements of ASME VIII, Division 2 and the responsibilities of various parties
- List the material requirements as well as material toughness and impact testing requirements
- Illustrate the design rules for internal pressure, buckling, formed and flat head and new method for design of openings and external loadings
- Employ stress analysis methods and acceptance criteria for design analysis
- Differentiate stress classifications and linearization as well as fatigue analysis and its exemption rules
- Simplify elastic-plastic analysis and list the various requirements for fabrication, PWHT, tolerances and NDE requirements
- Perform pressure testing, documentation and stamping
- Identify the pressure requirements and example problems

### **Who Should Attend**

This course provides an overview of all significant aspects and considerations of design, analysis, and fabrication of pressure vessels (ASME Code Section VIII, Division 2) for engineers with some background in structural design. However, experience with ASME Code is not mandatory as the course will cover the basics. The course could be attended by designers, fabricators, inspectors, and purchasers of vessels. Both the beginners and experienced personnel involved with pressure vessels will benefit from this course.

### **Training Methodology**

All our Courses are including **Hands-on Practical Sessions** using equipment, State-of-the-Art Simulators, Drawings, Case Studies, Videos and Exercises. The courses include the following training methodologies as a percentage of the total tuition hours:-

- 30% Lectures
- 20% Practical Workshops & Work Presentations
- 30% Hands-on Practical Exercises & Case Studies
- 20% Simulators (Hardware & Software) & Videos

In an unlikely event, the course instructor may modify the above training methodology before or during the course for technical reasons.



**Course Certificate(s)**

Internationally recognized certificates will be issued to all participants of the course who completed a minimum of 80% of the total tuition hours.

**Certificate Accreditations**

Certificates are accredited by the following international accreditation organizations:-

- 

The International Accreditors for Continuing Education and Training (IACET - USA)

Haward Technology is an Authorized Training Provider by the International Accreditors for Continuing Education and Training (IACET), 2201 Cooperative Way, Suite 600, Herndon, VA 20171, USA. In obtaining this authority, Haward Technology has demonstrated that it complies with the **ANSI/IACET 2018-1 Standard** which is widely recognized as the standard of good practice internationally. As a result of our Authorized Provider membership status, Haward Technology is authorized to offer IACET CEUs for its programs that qualify under the **ANSI/IACET 2018-1 Standard**.

Haward Technology’s courses meet the professional certification and continuing education requirements for participants seeking **Continuing Education Units (CEUs)** in accordance with the rules & regulations of the International Accreditors for Continuing Education & Training (IACET). IACET is an international authority that evaluates programs according to strict, research-based criteria and guidelines. The CEU is an internationally accepted uniform unit of measurement in qualified courses of continuing education.

Haward Technology Middle East will award **3.0 CEUs** (Continuing Education Units) or **30 PDHs** (Professional Development Hours) for participants who completed the total tuition hours of this program. One CEU is equivalent to ten Professional Development Hours (PDHs) or ten contact hours of the participation in and completion of Haward Technology programs. A permanent record of a participant’s involvement and awarding of CEU will be maintained by Haward Technology. Haward Technology will provide a copy of the participant’s CEU and PDH Transcript of Records upon request.

- 

British Accreditation Council (BAC)

Haward Technology is accredited by the **British Accreditation Council** for **Independent Further and Higher Education** as an **International Centre**. BAC is the British accrediting body responsible for setting standards within independent further and higher education sector in the UK and overseas. As a BAC-accredited international centre, Haward Technology meets all of the international higher education criteria and standards set by BAC.

**Course Fee**

**US\$ 6,000** per Delegate + **VAT**. This rate includes H-STK® (Haward Smart Training Kit), buffet lunch, coffee/tea on arrival, morning & afternoon of each day.

**Accommodation**

Accommodation is not included in the course fees. However, any accommodation required can be arranged at the time of booking.

### Course Instructor(s)

This course will be conducted by the following instructor(s). However, we have the right to change the course instructor(s) prior to the course date and inform participants accordingly:

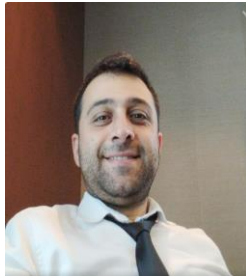

**Mr. Danny Gul** is a **Senior Inspection and Integrity Engineer** with extensive years of experience within the **Oil & Gas, Petrochemical, Process and Nuclear Industries** and provides **inspection, training, and consultancy in various areas**. His wide expertise lies extensively in the areas of **Risk Based Inspection and assessment (API 580), RBI Methodology (API 581), Fitness-for-Service (FFS) Assessment (API 579), Atmospheric & Low Pressure Storage Tank Inspection, reconstruction, alteration & Repair API 653, Welded Tanks for Oil Storage (API 650), Atmospheric & Low Pressure storage tank Inspection practices (API RP 575), Pressure Vessel Inspection Code: In-Service Inspection, Rating, Repair, and Alteration (API 510), Piping Inspection**

**Code: In-service Inspection, Rating, Repair, and Alteration of Piping (API 570), Inspection Practices for Piping System Components (API 574), Inspection of Pressure-relieving Devices (API 576), Welding Processes, Inspection, and Metallurgy (API 577), Damage Mechanisms Affecting Fixed Equipment in the Refining Industry (API 571), Guidelines for a Material Verification Program (API 578), American Society of Mechanical Engineers (ASME), Boiler and Pressure Vessel Code Section V, Nondestructive Examination, ASME Section IX, Welding, Brazing and Fusing, ASME B16.5, Pipe Flanges and Flanged Fittings, ASME B31.3, Process Piping, Inspection Practices for Pressure Vessels (API 572), ASME Section VIII, Rules for Construction of Pressure Vessels, Division 1 and Division 2, American Society of Mechanical Engineers (ASME) PCC-2, Repair of Pressure Equipment and Piping, API Recommended Practice 651, Cathodic Protection of Aboveground Petroleum Storage Tanks, API Recommended Practice 652, Lining of Aboveground Petroleum Storage Tank Bottoms, inspection of Fired Boilers and Heaters (API 573), Welding Guidelines for the Chemical, Oil, and Gas Industries (API 582), Corrosion Under Insulation and Fireproofing (API 583), Integrity Operating Windows (API 584), Design and Construction of Large, Welded, Low-Pressure Storage Tanks (API 620), Aboveground Storage Tank Caulking or Sealing the Bottom Edge, Projection to the Foundation (API 654), Venting Atmospheric and Low-Pressure Storage Tanks (API 2000), Valve Inspection and Testing (API 598), Std 1104 Welding of Pipelines and Related Facilities, RP 1169 Pipeline Construction Inspection, ASME BPVC Section II Materials, ASME PCC-1 Pressure Boundary Bolted Flange Joint Assembly, ASME PCC-3 Inspection Planning Using Risk-Based Methods, ASME B31.4 Pipeline Transportation Systems for Liquids and Slurries, ASME B31.8 Gas Transmission and Distribution Piping Systems, ASME B16.47 large-diameter-steel-flanged, Fabrication & Site Inspection, Site Erection Quality Control, Welding & Non-Destructive Testing (NDE), Hydro & Pneumatic Testing, Failure Mode & Effect Analysis (FMEA), Process Hazard Analysis (PHA), Human Factor Analysis, Hazard & Operability (HAZOP) Analysis, Layer of Protection Analysis (LOPA), QRA (Quantitative Risk Analysis), SIL (Safety Integrity Level) Evaluation, FTA (Fault Tree Analysis), ETA (Event Tree Analysis)**

During his Career Life, Mr. Gul has gained his practical and field experience through various significant positions and dedication as the **Head QA/QC, Inspection Specialist, Project Control Coordinator, Process Safety & Integrity Technical Expert, Nuclear Material & Equipment Inspector, Freelance API 653/580/571, EN ISO 9712 UT Level II and RT Level II complies with Pressure Equipment Directive (PED) 2014/68/EU Authorized Inspector/Consultant/Trainer** To provide **Supervision, Consultancy, Inspection, And Trainings** for numerous international and national companies like SLB (Previously known as Schlumberger), Assystem, American Petroleum Institute, TUV Nord, BOTAS Petroleum Pipeline Corporation (BOTAS), Abu Dhabi National Oil Company (ADNOC), QATAR GAS, BIL (BOTAŞ International Limited).

Mr. Gul has a **Bachelor's degree in Mechanical Engineering** from the **Istanbul Technical University, Turkey**. Further, he is a **Certified Instructor/Trainer, a Certified API 653 Aboveground Storage Tank Inspector, a Certified API 580 Risk Based Inspector a Certified API 571 Corrosion & Materials Inspector, a certified EN ISO 9712 UT and RT Level II complies with Pressure Equipment Directive (PED) 2014/68/EU**. He has further delivered numerous trainings, courses, seminars, conferences & workshops internationally.

### **Course Program**

The following program is planned for this course. However, the course director(s) may modify this program before or during the course for technical reasons with no prior notice to participants. Nevertheless, the course objectives will be always met:

#### **Day 1: Sunday, 22<sup>nd</sup> of June 2025**

0730 – 0800	<i>Registration &amp; Coffee</i>
0800 – 0815	<i>Welcome &amp; Introduction</i>
0815 – 0830	<b>PRE-TEST</b>
0830 – 0930	<b><i>Introduction to the ASME Boiler &amp; Pressure Vessel Code</i></b>
0930 – 0945	<i>Break</i>
0945 – 1100	<b><i>Comparison of Divisions 1 &amp; 2 of Section VIII</i></b>
1100 – 1215	<b><i>Theories of Failure &amp; Design Margins of Various Codes</i></b>
1215 – 1230	<i>Break</i>
1230 – 1330	<b><i>General Requirements of the New Division 2</i></b>
1330 – 1420	<b><i>Responsibilities of Various Parties</i></b>
1420 – 1430	<b>Recap</b>
1430	<i>Lunch &amp; End of Day One</i>

#### **Day 2: Monday, 23<sup>rd</sup> of June 2025**

0730 – 0830	<b><i>Materials Requirements</i></b>
0830 – 0930	<b><i>Material Toughness &amp; Impact Testing Requirements</i></b>
0930 – 0945	<i>Break</i>
0945 – 1100	<b><i>Design Rules for Internal Pressure</i></b>
1100 – 1215	<b><i>Design for Buckling</i></b>
1215 – 1230	<i>Break</i>
1230 – 1330	<b><i>Design of Formed &amp; Flat Head</i></b>
1330 – 1420	<b><i>New Method for Design of Openings</i></b>
1420 – 1430	<b>Recap</b>
1430	<i>Lunch &amp; End of Day Two</i>

#### **Day 3: Tuesday, 24<sup>th</sup> of June 2025**

0730 – 0830	<b><i>Design for External Loading</i></b>
0830 – 0930	<b><i>Stress Analysis Methods</i></b>
0930 – 0945	<i>Break</i>
0945 – 1100	<b><i>Acceptance Criteria for Design by Analysis</i></b>
1100 – 1215	<b><i>Stress Classification &amp; Stress Linearization</i></b>
1215 – 1230	<i>Break</i>
1230 – 1330	<b><i>Fatigue Analysis Exemption Rules</i></b>
1330 – 1420	<b><i>Fatigue Analysis</i></b>
1420 – 1430	<b>Recap</b>
1430	<i>Lunch &amp; End of Day Three</i>

#### **Day 4: Wednesday, 25<sup>th</sup> of June 2025**

0730 – 0930	<b><i>Simplified Elastic – Plastic Analysis</i></b>
0930 – 0945	<i>Break</i>
0945 – 1100	<b><i>Fabrication Requirements</i></b>
1100 – 1215	<b><i>PWHT Requirements</i></b>

1215 - 1230	Break
1230 - 1330	<b>Tolerances</b>
1330 - 1420	<b>NDE Requirements</b>
1420 - 1430	<b>Recap</b>
1430	Lunch & End of Day Four

**Day 5: Thursday, 26<sup>th</sup> of June 2025**

0730 - 0930	<b>Pressure Testing</b>
0945 - 1100	<b>Documentation &amp; Stamping</b>
0930 - 0945	Break
0945 - 1100	<b>Pressure Relief Requirements</b>
1100 - 1215	<b>Example Problems</b>
1215 - 1230	Break
1230 - 1345	<b>Discussion</b>
1345 - 1400	<b>Course Conclusion</b>
1400 - 1415	<b>POST-TEST</b>
1415 - 1430	<b>Presentation of Course Certificates</b>
1430	Lunch & End of Course

**Simulator (Hands-on Practical Sessions)**

Practical sessions will be organized during the course for delegates to practice the theory learnt. Delegates will be provided with an opportunity to carryout various exercises using the state-of-the-art “COMPRESS” simulator.

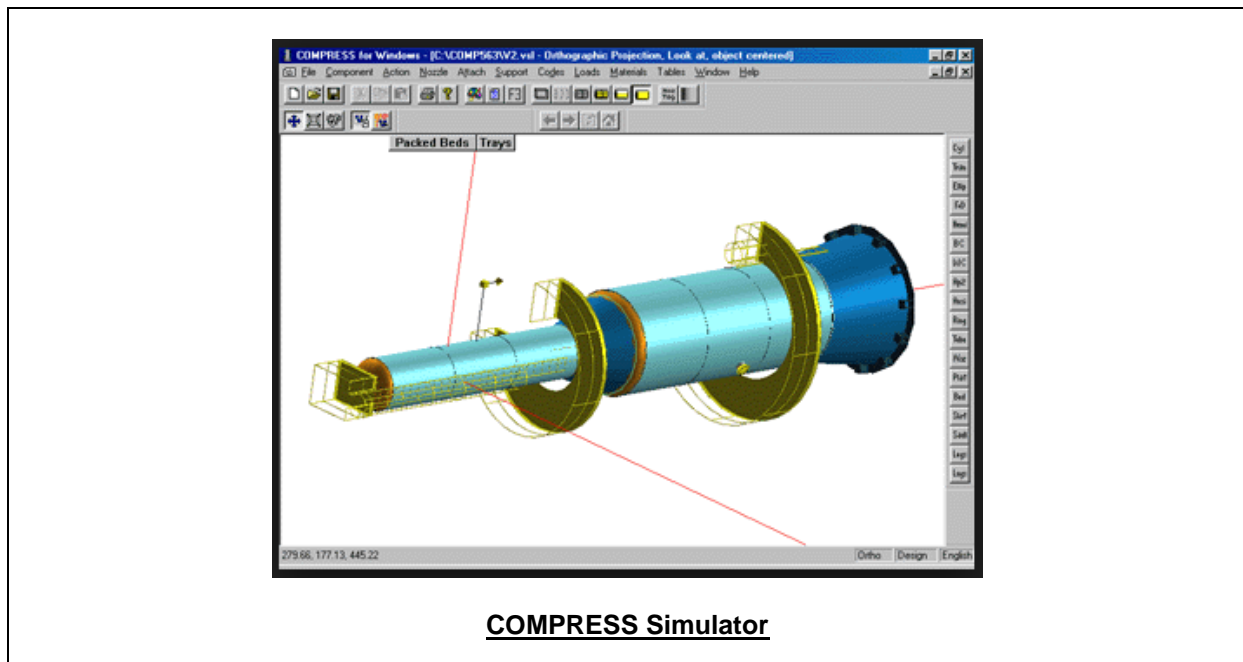

**Course Coordinator**

Mari Nakintu, Tel: +971 2 30 91 714, Email: [mari1@haward.org](mailto:mari1@haward.org)